



*Prices effective
September 1, 2011*

Global Series™ Air Cylinders



NOW LOOK AT ALL YOU GET



Here is FABCO-AIR's Expanded Line of Space Saving Air Cylinders

Innovation – For 40 years our famous Pancakes® have dominated as the world's first compact air cylinder line. Today, backed by decades of engineering innovation, our new Global Series™ extruded body cylinders continue in the Pancake® tradition with exceptional performance and the widest available selection of models and options.

Packed with Value – Tough, rigid, hard anodized aluminum extrusions house oversized hard chrome stainless steel piston rods for service to 10 bar (150 psi). Magnetic piston position sensing enables mid-stroke signaling and exact end-of-stroke sensing. Multiple dovetails each accommodate multiple switches without the need for switch mounting brackets.

Duralon® Rod Bearings Excel

Load Capacity (psi)	Friction Properties	
	Coefficient	Slip-stick
Machine Design 1972/73 Bearing Reference Issue		
Porous Bronze..... 4,500	Steel-on-steel..... .50	Yes
Porous iron..... 8,000	Bronze-on-steel..... .35	Yes
Phenolics..... 6,000	Sintered Bronze-on-steel	
Nylon®..... 1,000	with mineral oil..... .13	No
TFE..... 500	Bronze-on-steel	
Reinforced Teflon®..... 2,500	with mineral oil..... .16	No
*TFE fabric..... 60,000	Copper lead alloy-on-steel..... .22	Yes
Polycarbonate..... 1,000	Acetal-on-steel..... .20	No
Acetal..... 1,000	Nylon-on-steel..... .32	Yes
Carbon-graphite..... 600	Duralon-on-steel..... .05 - .16	No

* Shows Duralon bearing classification. Not to be used for design purposes.

Printed with permission by Rexnord Corp.

Extra Long Piston Rod Bearing – The better the bearing is, the more cycle life you can expect from your cylinders. And Global Series™ Cylinders incorporate a truly superior rod bearing material – Duralon® with the same field-proven performance you have come to expect from the five other Fabco-Air cylinder families.

Duralon® is a composite of a Teflon®/Dacron fabric liner bonded to a supporting filament-wound, high strength, fiberglass and epoxy resin shell. Resistant to corrosion, moisture and temperature to 325°, Duralon is reliable in any environment. It has an extremely high load bearing capacity, very low friction, and will not gall or score the piston rod (See physical properties in the above table).

Performance and the Widest Selection of Models & Options

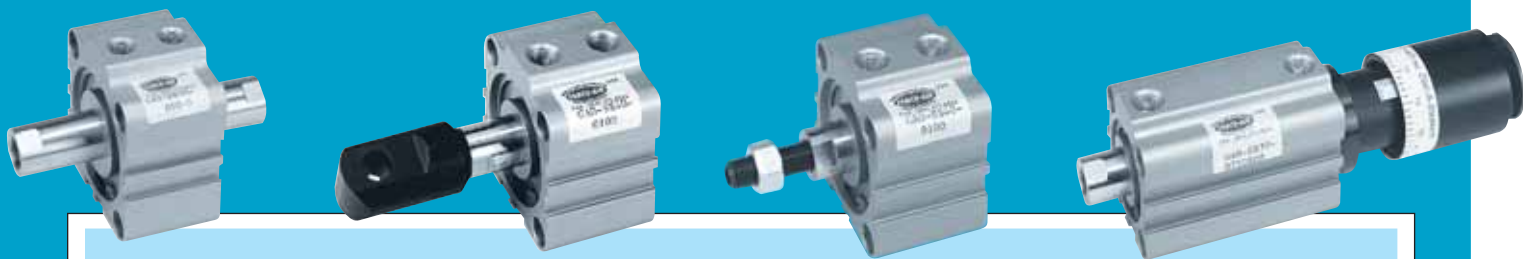

PRODUCT INDEX

Global Series™

How to order	9
Standard Stroke & Options Availability	4, 5
Effective Piston Areas, Weights	8
Construction and Parts Lists	6, 7
Double Acting Dimensions	
Single Rod	10, 11
Double Rod	12, 13
Double Rod, Hole Thru	12, 16
Nonrotating Piston Rod	14 - 17
Single Acting Dimensions	
Spring Retract/Spring Extend	18, 19
Spring forces	8



Global Series™ with Magnetic Piston Position Sensing

Double Acting Dimensions	
Single Rod	20, 21
Double Rod	22, 23
Double Rod, Hole Thru	22, 26
Nonrotating Piston Rod	24 - 27

Cylinder Options & Accessories

Adjustable Stroke Extend	28, 29
Adjustable Stroke Retract	35
Back to Back Cylinders	34, 35
Tandem Cylinders	34, 35
High Temperature Seals	35
Magnetic Piston Position Sensors	37
Female Cordsets for Quick Disconnects	37
Mounting Options	
Foot Mount	31
Boss Mount, Front & Rear	33
Flange Mounts, Front & Rear	32
Rear Clevis Mount	30
Rod Clevis	36
Rod Eye	36
Seal Kits	35

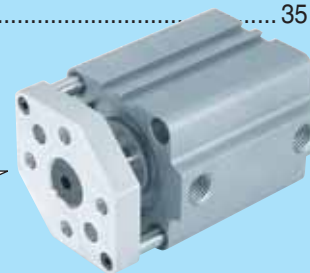

Global Series™ Guided Toolplate

Features	38
How to Order	39
Specifications & Dimensions	39 - 43

Supported by engineering and inventory –

Cylinder components are on the shelf. CAD libraries of drawings for each model and option are available on disk and at our web site ready for downloading. We're ready to work with you.

Phone: (352) 373-3578; Web site <http://www.fabco-air.com>;
E-Mail: fabco@fabco-air.com.

Plenty to Choose From –

- 10 bore sizes – 12 through 100 mm (1/2" – 4").
- Strokes – 5 through 150 mm (.2" – 6").
- 3 Choices of ports – NPT, BSP Parallel, BSP Tapered.
- Choice of rod ends – female with wrench flats or male rod with wrench flats and jam nut.

- Metric or Inch rod thread and mounting.
- Actuation – double acting, single rod; double acting, double rod; non-rotating double acting, single rod or double rod; single acting, single rod – spring retract or spring extend.
- Magnetic piston models for position sensors including electronic sensors and reed switches.
- 10 mounting accessories – including flange mounts (rod or cap end with ISO or Non-ISO pattern), rear clevis mount (rear clevis, rod clevis, rod eye), boss mount (rod or cap), and foot mounts.
- Unique, adjustable stroke models.
- 3-position and 4-position models.
- Bumpers and choice of seal materials. . .

all backed by a 32 month, 11 million cycle warranty!

Global Series™ Cylinders

Standard Strokes

Note: Use internal stroke collar to obtain intermediate stroke from longer stroke cylinders.
Stroke tolerances ■ 12 thru 100 Bore + 1.0 mm / - 0

Actuation	Standard Mounting	Stroke (mm)	5	10	15	20	25	30	35	40	45	50	75	100	125	150			
		Bore Size (mm)	12	✓	✓	✓	✓	✓	✓	✓	✓	✓	✓	✓	✓	✓	✓		
			16	✓	✓	✓	✓	✓	✓	✓	✓	✓	✓	✓	✓	✓	✓		✓
			20	✓	✓	✓	✓	✓	✓	✓	✓	✓	✓	✓	✓	✓	✓		✓
			25	✓	✓	✓	✓	✓	✓	✓	✓	✓	✓	✓	✓	✓	✓		✓
			32	✓	✓	✓	✓	✓	✓	✓	✓	✓	✓	✓	✓	✓	✓		✓
		Bore Size (mm)	40	✓	✓	✓	✓	✓	✓	✓	✓	✓	✓	✓	✓	✓	✓		
			50	✓	✓	✓	✓	✓	✓	✓	✓	✓	✓	✓	✓	✓	✓		✓
			63	✓	✓	✓	✓	✓	✓	✓	✓	✓	✓	✓	✓	✓	✓		✓
			80	✓	✓	✓	✓	✓	✓	✓	✓	✓	✓	✓	✓	✓	✓		✓
			100	✓	✓	✓	✓	✓	✓	✓	✓	✓	✓	✓	✓	✓	✓		✓
		Bore Size (mm)	12	✓	✓	✓	✓	✓	✓	✓	✓	✓	✓	✓	✓	✓	✓		
			16	✓	✓	✓	✓	✓	✓	✓	✓	✓	✓	✓	✓	✓	✓		✓
			20	✓	✓	✓	✓	✓	✓	✓	✓	✓	✓	✓	✓	✓	✓		✓
			25	✓	✓	✓	✓	✓	✓	✓	✓	✓	✓	✓	✓	✓	✓		✓
			32	✓	✓	✓	✓	✓	✓	✓	✓	✓	✓	✓	✓	✓	✓		✓
		Bore Size (mm)	40	✓	✓	✓	✓	✓	✓	✓	✓	✓	✓	✓	✓	✓	✓		
			50	✓	✓	✓	✓	✓	✓	✓	✓	✓	✓	✓	✓	✓	✓		✓
			63	✓	✓	✓	✓	✓	✓	✓	✓	✓	✓	✓	✓	✓	✓		✓
			80	✓	✓	✓	✓	✓	✓	✓	✓	✓	✓	✓	✓	✓	✓		✓
			100	✓	✓	✓	✓	✓	✓	✓	✓	✓	✓	✓	✓	✓	✓		✓
		Bore Size (mm)	12	✓	✓														
			16	✓	✓														
			20	✓	✓														
			25	✓	✓														
			32	✓	✓														
		Bore Size (mm)	40	✓	✓														
			50	✓	✓														
			63	✓	✓														
			80	✓	✓														
			100	✓	✓														

Standard Strokes, Features & Options Availability

Features and Options

Standard Series	Magnetic Piston Series	Mounting Options						Cylinder Options			
		Tapped Hole	Flange Mounts	Foot Mount	Rear Clevis Mount	Front Boss Mount	Rear Boss Mount	Male Rod End	Adjustable Stroke	High Temp Seals	Bumpers

Double Acting Single Rod

✓	✓	✓	✓	✓	✓	✓	✓	✓	✓	✓	✓
---	---	---	---	---	---	---	---	---	---	---	---

Double Acting Double Rod

✓	✓	✓	✓	✓		✓	✓	✓		✓	✓
---	---	---	---	---	--	---	---	---	--	---	---

Double Acting, Single Rod Non-Rotating

✓	✓	✓	✓	✓	✓	✓	✓	✓	✓	✓	✓
---	---	---	---	---	---	---	---	---	---	---	---

Double Acting, Double Rod Non-Rotating

✓	✓	✓	✓	✓		✓	✓	✓		✓	✓
---	---	---	---	---	--	---	---	---	--	---	---

Single Acting Spring Retract

✓		✓	✓	✓	✓			✓		✓	
---	--	---	---	---	---	--	--	---	--	---	--

Single Acting Spring Extend

✓		✓	✓	✓	✓			✓		✓	
---	--	---	---	---	---	--	--	---	--	---	--

Standard Cylinder Models

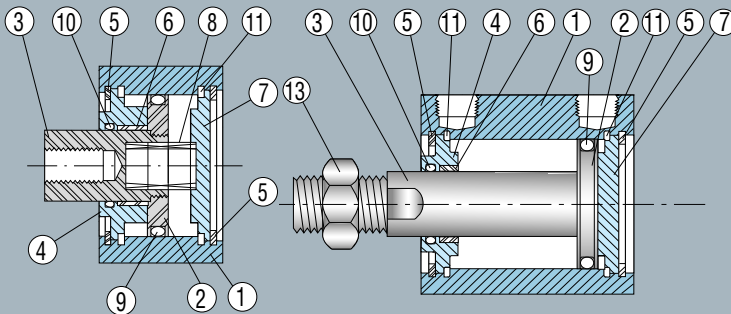

Single Acting/Spring Extend

Single Rod/Double Acting
Male Rod Thread Optional

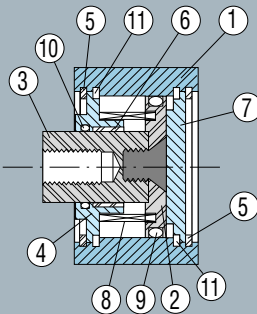

Single Acting/Spring Retract

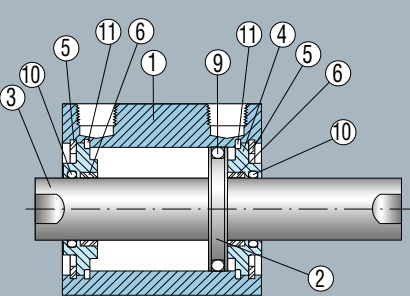

Double Rod/Double Acting

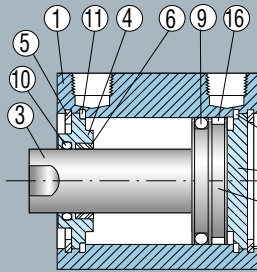

Extended Strokes

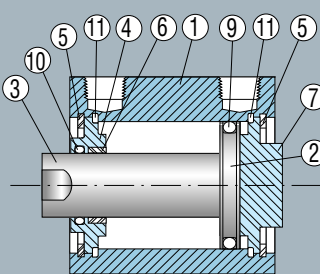

Single Rod/Boss Mount

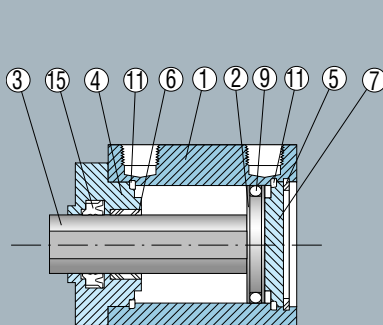

Single Rod/Nonrotating

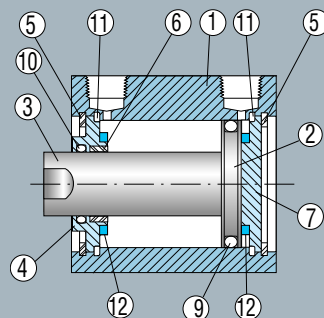

Single Rod/Bumpers
Front & Rear

Basic Construction

Quick Reference to Components

No.	Description	Material	Note
1	Cylinder body	Hard Anodized Aluminum	Extruded with dovetails
2	Piston	Aluminum alloy	
3	Piston rod	Stainless steel	Hard chrome plated
4	Bushing cap	Aluminum alloy	Black anodized
5	Lock ring	Carbon steel	Zinc chromate
6	Rod bearing	Duralon®	See note 1 below
7	End cap	Aluminum alloy	Black anodized
8	Spring	Music wire	
9	Piston seal	Internal lube O-ring	Viton optional
10	Rod seal	Internal lube O-ring	Viton optional
11	Gasket	Buna N	Viton optional
12	Bumper	Rubber	
13	Rod end nut	Carbon steel	Plated
14	Annular magnet	Rubber bonded	See notes 2 & 3 below
15	Rod seal	Buna N	Molded shape – U cup
16	Bearing strip	TFE compound	See page 7

Note 1: Bearing material for 12, 16 & 20 mm bores is hard anodized aluminum

Note 2: Magnetic material 12, 16 & 20mm bores: rare earth neodymium

Note 3: Magnetic material 25mm bore and up: barium ferrite

Cylinder Body Material – is a custom aluminum extrusion with integral dovetail slots to provide mounting for piston position sensors. Its heavy wall prohibits damage to the bore from external influences.

The Bore is Polished – to produce a fine crosshatch finish. This finish, unlike an ultra-smooth finish, provides minute oil rings in which the lubrication can lie and support the seal as it moves along the surface. This surface finish and lubrication lowers friction and prolongs seal life.

The Cylinder is Hard Anodized – inside and out. Hard anodizing is an electrochemical process which provides a very dense surface of aluminum oxide that actually impregnates the base aluminum. It forms an extremely hard (60 Rc) surface with a low coefficient of friction. Hardness, corrosion resistance and wear resistance exceeds that of chrome plated steel.

An Extra Long Rod Bearing – provides long and rigid support for the piston rod. The bearing material is Hard Anodized Aluminum on the small 12, 16 & 20 mm bores, and Duralon® on all larger bore sizes. See the chart comparing physical properties on page 2. The bushing cap and end cap are held in place by a locking ring.

The Piston Rod – is Hard Chrome Plated Stainless Steel. The standard rod end is fine thread tapped and has long wrench flats.

Piston Construction – The piston is aluminum for light weight. A counterbore locates the piston rod with precise concentricity for smooth cylinder performance.

For single rod cylinders – the piston is attached to the piston rod with a socket flat head screw which is torqued for both proper preload on the screw and secure clamping

Air Cylinders with 35 Years Manufacturing Experience Built-in

of the piston. Loctite® on the threads and faces assures sealing and locks the assembly against pounding and vibration.

For double rod cylinders – the piston rods are connected by a high strength stud, sandwiching the piston between the rod end faces. Counterbores locate the rods for alignment and precise concentricity. The assembly is torqued and Loctited®.

Standard & Long Stroke Cylinder Pistons– are thin with a single O-ring for space savings.

Extended Stroke Cylinder Pistons – are thicker and incorporate a bearing in addition to the O-ring seal. The bearing is a close tolerance, rectangular cross section strip of a tough, stable, wear-resistant TFE compound located at the rear of the piston head, the furthest point from the rod bearing. The bearing material and its location provide maximum load support and maintain the long life of the cylinder bore and piston seal.

Standard Seals are Internally Lubricated, Modified Buna N O-rings – Benefits include low profile cylinder construction, low friction, and long life sealing over an operating temperature range of -32°C to $+121^{\circ}\text{C}$ (-25°F to $+250^{\circ}\text{F}$). Additionally, all units are factory lubricated with Magnalube®-G, a grease loaded with microscopic size particles of TFE in suspension. This combination has been found suitable for long life in most non-lube service applications.

Viton seals are optional for high temperature resistance (204°C and 400°F) and resistance to many hostile fluids.

Magnetic Piston Cylinders

Magnetic Piston Position Sensing – enables mid-stroke signaling and exact end-of-stroke sensing.

When the magnetic piston moves under a sensor the magnetic field activates the sensor without physical contact. A sensor can be positioned anywhere in one of the dovetail slots and locked in position by an integral screw. Multiple sensors can be installed in one or more of the dovetails.

The sensor(s) provides precise piston position indication for controllers, computers, relays, valves, or other devices. (See page 37 for sensor models)

For 25mm bore cylinders and up, a polarized permanent magnet of rubber bonded barium ferrite is used. It is very stable and unaffected by vibration and shock. Under normal usage it will remain magnetized indefinitely.

For 12mm, 16mm and 20mm bores (which have higher ratios of cylinder wall thickness to piston diameter) a rare earth neodymium magnetic material is used to assure consistently reliable sensor performance.

External magnetic fields and/or magnetic conductive materials may affect the strength of the piston magnets, therefore affecting sensor actuation and piston position indication.

When a sensor is mounted to indicate a mid-stroke position, the moving piston causes the sensor to provide a momentary signal. If signal duration is less than, or marginally close to what is required for the driven device a user-supplied latching circuit (or similar) may be needed.

Duralon® is a registered trademark of Rexnord Corp.

Loctite® is a registered trademark of Loctite Corp.

Magnalube®-G is a registered trademark of Carlton Stuart Corp.

Teflon® and Viton® are registered trademarks of DuPont Corp.

10-22-04

Specifications subject to change without notice or incurring obligation.

Magnetic Piston Models

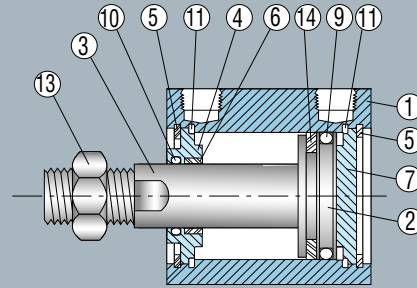

Single Rod/Double Acting
Male Rod Thread Optional

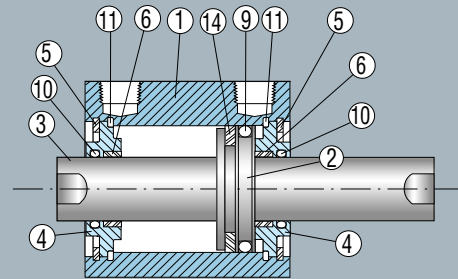

Double Rod/Double Acting

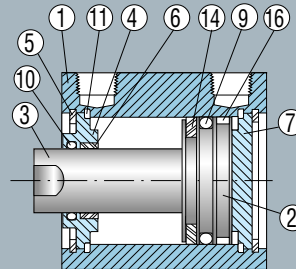

Extended Strokes

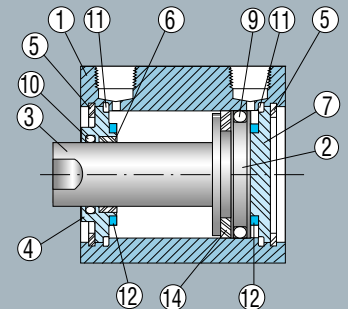

Single Rod/Double Acting
Bumpers Front and Rear

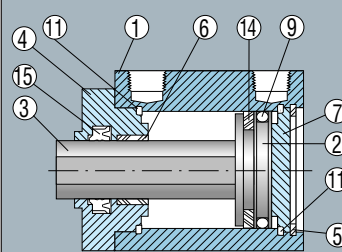

Single Rod/Nonrotating

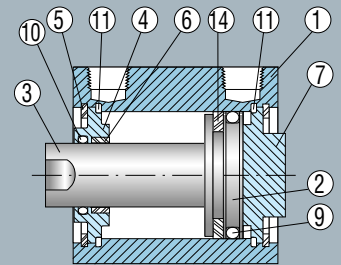

Single Rod/Double Acting
Rear Boss Mount

Global Series™ Cylinders

– Specifications

Effective Piston Areas				
Bore – mm	Push		Pull	
	cm ²	in ²	cm ²	in ²
12	1.1	.17	.8	.13
16	2.0	.31	1.5	.23
20	3.1	.49	2.4	.37
25	4.9	.76	3.8	.59
32	8.0	1.25	6.0	.94
40	12.6	1.95	10.6	1.64
50	19.6	3.04	16.4	2.56
63	31.2	4.83	28.0	4.35
80	50.3	7.79	45.4	7.03
100	78.5	12.17	71.4	11.08

Spring Retract Forces				
Bore – mm	Pre-load		End of Stroke	
	kg	lbs	kg	lbs
12	0.4	0.9	1.4	3.1
16	0.6	1.3	1.5	3.3
20	0.6	1.3	1.6	3.5
25	1.1	2.4	2.1	4.6
32	1.5	3.3	2.4	5.3
40	1.3	2.9	3.1	6.8
50	2.5	5.5	5.5	12.1

Spring Extend Forces				
Bore – mm	Pre-load		End of Stroke	
	kg	lbs	kg	lbs
12	0.3	0.7	1.1	2.4
16	0.4	0.9	2.1	4.6
20	0.5	1.1	3.0	6.2
25	1.0	2.2	3.0	6.6
32	2.0	4.4	3.0	6.6
40	2.0	4.4	3.0	6.6
50	2.5	5.5	8.5	18.7



Conversions	
<i>Multiply by</i>	
Newton	0.102..... Kg (force)
lb (force)	4.448..... Newton
lb (force)	0.454..... Kg (force)
psi	0.069..... bar
Force (lb) = P (psi) x A (in ²)	
Force (Newton) = P (bar) x A (cm ²) x 10	

Estimated Cylinder Weights - Double Acting, Single Rod Models										
Note: Weights in Grams (Pounds)										
Bore mm	Strokes in millimeters								Additional weight for male thread	Additional weight for magnetic piston
	5	10	30	50	75	100	125	150		
12	40 (0.088)	47 (.104)	75 (.165)	109 (.240)	140 (.309)	172 (.378)	–	–	2 (.004)	12 (.03)
16	61 (0.135)	72 (.159)	116 (.256)	160 (.353)	204 (.450)	248 (.546)	–	–	3 (.007)	17 (.04)
20	91 (0.201)	112 (.247)	193 (.426)	254 (.559)	311 (.684)	375 (.826)	–	–	7 (.015)	25 (.05)
25	118 (0.260)	139 (.306)	224 (.494)	287 (.631)	408 (.899)	484 (1.067)	–	–	17 (.04)	29 (.06)
32	157 (0.346)	180 (.397)	270 (.595)	339 (.746)	522 (1.15)	636 (1.40)	824 (1.81)	936 (2.06)	40 (.09)	39 (.09)
40	272 (0.600)	294 (.648)	382 (.842)	448 (.986)	623 (1.37)	733 (1.62)	1077 (2.37)	1211 (2.67)	40 (.09)	54 (.12)
50	–	401 (.884)	551 (1.21)	663 (1.46)	958 (2.11)	1102 (2.43)	1848 (4.07)	2066 (4.55)	80 (.18)	80 (.18)
63	–	647 (1.43)	807 (1.78)	927 (2.04)	1257 (2.77)	1464 (3.23)	2243 (4.94)	2499 (5.51)	80 (.18)	102 (.24)
80	–	1443 (3.18)	1804 (3.98)	2076 (4.57)	2830 (6.24)	3296 (7.27)	3494 (7.70)	3870 (8.52)	160 (.35)	143 (.31)
100	–	2208 (4.87)	2632 (5.80)	2950 (6.49)	3801 (8.38)	4318 (9.52)	5036 (11.10)	5531 (12.18)	270 (.60)	282 (.62)

Model Number	Series	Port	Body	Model	Mounting	Bore	Stroke	Action	Options
	G- Global Series™		N- without magnetic piston D- with magnetic piston					D- double acting S- single acting, spring retract - 012 thru 050 bore only T- single acting, spring extend - 012 thru 050 bore only	
	N- NPT ports, inch rod thread G- BSP Parallel ports, metric rod thread P- BSPT taper ports, metric rod thread		S- single rod W- double rod T- double rod hole thru K- non-rotating single rod L- non-rotating double rod M- non-rotating double rod hole thru A- adjustable stroke extend AK- adjustable stroke extend nonrotating rod (Note 1)	B- thru hole L- foot mount E- flange rod end F- flange cap end G- ISO flange rod end H- ISO flange cap end C- rear clevis A- tapped both ends (Note 2)		012 016 020 025 032 040 050 063 080 100	005 100 005 150 010 150	B- bumpers, both ends M- male rod, rod end N- male rod, cap end P- male rod, both ends E- boss, rod end F- boss, cap end *RS- adjustable stroke, retract ‡Available only for S & K models V- high temperature seals XC10- back-to-back XC11- tandem (mtg at rod end) XC12- tandem (mtg at cap end)	
	Note 1: See page 28 for specific 'AK' information and ordering examples					Note 2: On bores 12 – 100mm, tapped holes will be inch threads for port code 'N' and metric threads for port codes 'G' & 'P'. Tapped holes will be metric when ordering any foot, flange, or clevis mounting.		Note 3	



Ordering Example 1 – Global Series™, NPT Ports, without Magnetic Piston, Single Rod, ISO Flange on Rod End, 25mm Bore, 60mm Stroke, Double Acting, and Male Rod. **Note: The standard stroke chart on page 4 shows available strokes of 50mm and 75 mm. A 60mm stroke is obtained using an internal stroke collar with the longer 75mm stroke cylinder. (See extended stroke chart on page 10 for A and B dimensions which apply to the 75mm cylinder body).**

The Model Number is:
GNN – SG025 – 060D – M



Ordering Example 2 – Global Series™, NPT Ports, with Magnetic Piston, Single Rod, Through Hole Standard Mount, 50mm Bore, 75mm Stroke, Double Acting, Male Rod, and High Temperature Seals. **Note: The standard stroke chart on page 4 shows 75mm stroke is available. No stroke collar is required.**

The Model Number is:
GND – SB050 – 075D – M – V

Note: Sensors must be ordered separately. See page 37.

Global Series™ Cylinders



Ø12 - Ø25 mm Bores

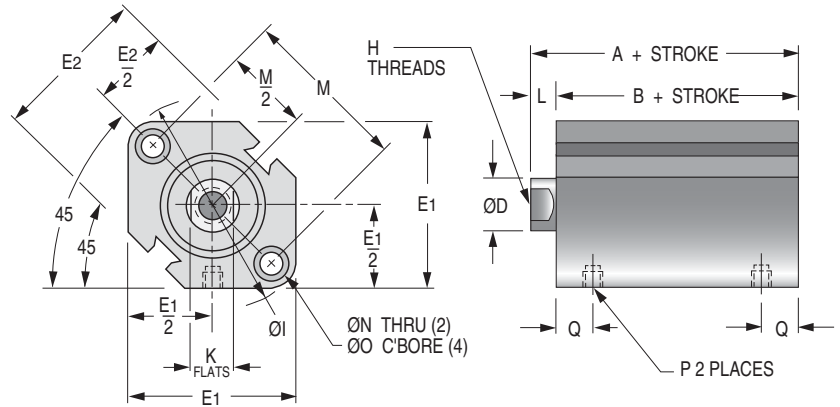

Dimensional Data

Note 1- See page 4 for complete stroke availability
 Note 2- Chart dimensions are shown as mm (inches)

Bore mm	Long Stroke				Extended Stroke			
	Stroke mm	A	B	Q	Stroke mm	A	B	Q
12	-	-	-	-	50, 75, 100	37.3 (1.47)	33.8 (1.33)	8.9 (.35)
16	-	-	-	-	50, 75, 100	39.7 (1.56)	36.2 (1.42)	10.2 (.40)
20	-	-	-	-	75, 100	46.1 (1.82)	41.6 (1.64)	12.1 (.48)
25	-	-	-	-	75, 100	52.5 (2.07)	47.5 (1.87)	12.7 (.50)
32	75, 100	40.0 (1.57)	33.0 (1.30)	8.7 (.34)	125, 150	54.8 (2.16)	47.8 (1.88)	12.7 (.50)
40	75, 100	46.5 (1.83)	39.5 (1.56)	9.2 (.36)	125, 150	62.5 (2.46)	55.5 (2.19)	12.7 (.50)
50	75, 100	48.5 (1.91)	40.5 (1.59)	10.5 (.41)	125, 150	67.3 (2.65)	59.3 (2.33)	13.2 (.52)
63	75, 100	54.0 (2.13)	46.0 (1.81)	11.5 (.45)	125, 150	72.6 (2.86)	64.6 (2.54)	18.5 (.73)
80	75, 100	63.5 (2.50)	53.5 (2.11)	14.0 (.55)	125, 150	79.5 (3.13)	69.5 (2.74)	14.0 (.55)
100	75, 100	75.0 (2.95)	63.0 (2.48)	18.0 (.71)	125, 150	88.7 (3.49)	76.7 (3.02)	18.0 (.71)

Bore mm (Nom. Inch)	Stroke Range	A	B	ØD	E1	E2	H (Threads) x dp minimum inch or metric	ØI
12 (1/2)	5~30 (0.20~1.18)	20.5 (0.81)	17.0 (0.67)	6 (0.236)	25 (0.98)	23 (0.90)	#8-32 x .21dp M3 x 0.5 - 5 dp	31.5 (1.24)
16 (5/8)	5~30 (0.20~1.18)	22.0 (0.87)	18.5 (0.73)	8 (0.315)	29 (1.14)	27.2 (1.07)	#8-32 x .21dp M4 x 0.7 - 5 dp	37.1 (1.46)
20 (3/4)	5~50 (0.20~2.0)	24.0 (0.94)	19.5 (0.77)	10 (0.394)	36 (1.42)	31.2 (1.23)	#10-32 x .28 dp M5 x 0.8 - 7 dp	47 (1.85)
25 (1)	5~50 (0.20~2.0)	27.5 (1.08)	22.5 (0.89)	12 (0.472)	40 (1.57)	36.9 (1.45)	1/4-28 x .39 dp M6 x 1.0 - 10 dp	51.3 (2.02)
32 (1-1/4)	5 only (0.20)	30.0 (1.18)	23.0 (0.91)	16 (0.630)	44.5 (1.75)	-	5/16-24 x .50 dp M8 x 1.25 - 12 dp	58.9 (2.32)
	10~50 (0.39~2.0)	30.0 (1.18)	23.0 (0.91)	16 (0.630)	44.5 (1.75)	-	5/16-24 x .50 dp M8 x 1.25 - 12 dp	58.9 (2.32)
40 (1-1/2)	5~50 (0.20~2.0)	36.5 (1.44)	29.5 (1.16)	16 (0.630)	52 (2.05)	-	3/8-24 x .50 dp M8 x 1.25 - 12 dp	69 (2.72)
50 (2)	10~50 (0.39~2.0)	38.5 (1.52)	30.5 (1.20)	20 (0.787)	63.7 (2.51)	-	1/2-20 x .50 dp M10 x 1.5 - 12 dp	84.9 (3.34)
63 (2-1/2)	10~50 (0.39~2.0)	44.0 (1.73)	36.0 (1.42)	20 (0.787)	76.7 (3.02)	-	1/2-20 x .50 dp M10 x 1.5 - 12 dp	101.8 (4.01)
80 (3-1/4)	10~50 (0.39~2.0)	53.5 (2.11)	43.5 (1.71)	25 (0.984)	97.8 (3.85)	-	5/8-18 x .88 dp M16 x 2.0 - 22 dp	129.8 (5.11)
100 (4)	10~50 (0.39~2.0)	65.0 (2.56)	53.0 (2.09)	30 (1.181)	115.3 (4.54)	-	3/4-16 x .88 dp M20 x 2.5 - 22 dp	153.9 (6.06)

Double Acting, Single Rod Models



Ø32 - Ø100 mm Bores

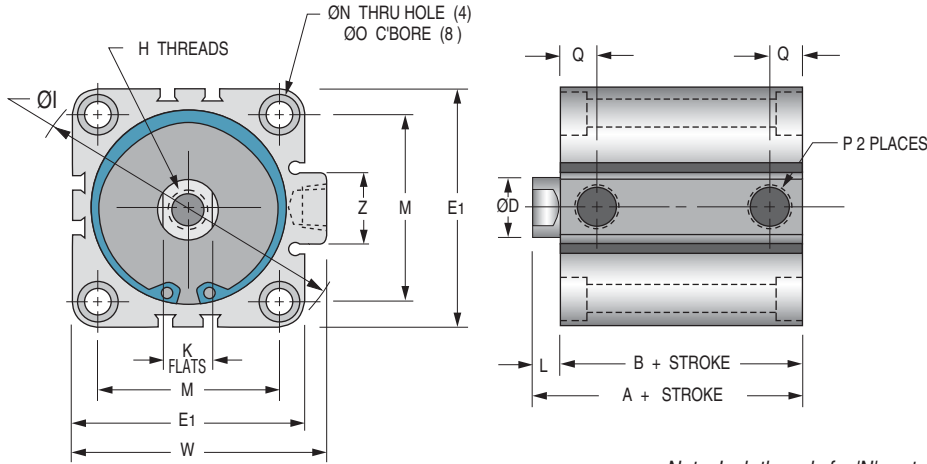

* Port Size Offerings

See dim. column "P" below

- N**- NPT ports, inch rod thread
 - G**- BSP parallel ports, metric rod thread
 - P**- BSPT taper ports, metric rod thread
- Note: M5 x 0.8 port will accept #10-32 male thread fittings.

Note: Inch threads for 'N' port code.
Metric threads for 'G' & 'P' port codes.
Metric for foot, flange, or clevis mount.

Rod end male thread

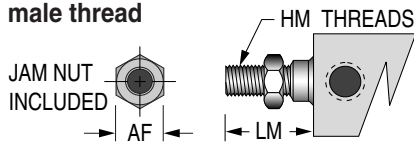

Bore mm	AF (HEX) inch or mm	HM (THREADS) inch or metric	LM inch or mm
12	.34 or 8	#8-32 x .31 lg or M5 x 0.8 - 9 lg	0.45 or 14.0
16	.34 or 10	#8-32 x .31 lg or M6 x 1.0 - 10 lg	0.45 or 15.5
20	.38 or 13	#10-32 x .31 lg or M8 x 1.25 - 12 lg	0.49 or 18.5
25	.43 or 17	1/4-28 x .37 lg or M10 x 1.25 - 15 lg	0.57 or 22.5
32	.50 or 22	5/16-24 x .50 lg or M14 x 1.5 - 20.5 lg	0.78 or 28.5
40	.56 or 22	3/8-24 x .63 lg or M14 x 1.5 - 20.5 lg	0.91 or 28.5
50	.75 or 27	1/2-20 x .77 lg or M18 x 1.5 - 26 lg	1.08 or 33.5
63	.75 or 27	1/2-20 x .77 lg or M18 x 1.5 - 26 lg	1.08 or 33.5
80	.93 or 32	5/8-18 x 1.00 lg or M22 x 1.5 - 32.5 lg	1.40 or 43.5
100	1.13 or 46	3/4-16 x 1.12 lg or M26 x 1.5 - 32.5 lg	1.59 or 43.5

Tapped hole mounting

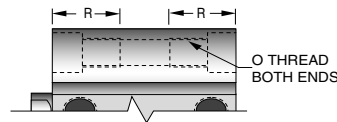

Bore mm	O (THREADS) inch or metric	R inch or mm
12	#8-32 or M4 x 0.7	0.43 or 11
16	#8-32 or M4 x 0.7	0.43 or 11
20	1/4-20 or M6 x 1.0	0.67 or 17
25	1/4-20 or M6 x 1.0	0.67 or 17
32	1/4-20 or M6 x 1.0	0.67 or 17
40	1/4-20 or M6 x 1.0	0.75 or 19
50	5/16-18 or M8 x 1.25	0.75 or 19
63	7/16-14 or M10 x 1.5	0.87 or 22
80	1/2-13 or M12 x 1.75	1.13 or 29
100	1/2-13 or M12 x 1.75	1.13 or 29

K	L	M	ØN	ØØ	*P	Q	W	Z	Bore mm (Nom. Inch)
5 (0.20)	3.5 (0.14)	22 (0.87)	3.5 (0.14)	6.5 x 3.5 dp (0.26 x 0.14 dp)	M5x0.8	7.0 (0.28)	-	-	12 (1/2)
6 (0.24)	3.5 (0.14)	28 (1.10)	3.5 (0.14)	6.5 x 3.5 dp (0.26 x 0.14 dp)	M5x0.8	7.8 (0.31)	-	-	16 (5/8)
8 (0.31)	4.5 (0.18)	36 (1.42)	5.5 (0.22)	9.0 x 7.0 dp (0.35 x 0.28 dp)	M5x0.8	8.1 (0.32)	-	-	20 (3/4)
10 (0.39)	5 (0.20)	40 (1.57)	5.5 (0.22)	9.0 x 7.0 dp (0.35 x 0.28 dp)	M5x0.8	8.4 (0.33)	-	-	25 (1)
14 (0.55)	7 (0.28)	34 (1.34)	5.5 (0.22)	9.0 x 7.0 dp (0.35 x 0.28 dp)	M5x0.8	8.7 (0.34)	49.3 (1.94)	16.5 (0.65)	32 (1-1/4)
14 (0.55)	7 (0.28)	34 (1.34)	5.5 (0.22)	9.0 x 7.0 dp (0.35 x 0.28 dp)	1/8*	8.7 (0.34)	49.3 (1.94)	16.5 (0.65)	
14 (0.55)	7 (0.28)	40 (1.57)	5.5 (0.22)	9.0 x 7.0 dp (0.35 x 0.28 dp)	1/8*	9.2 (0.36)	57.0 (2.24)	17.8 (0.70)	40 (1-1/2)
17 (0.67)	8 (0.31)	50 (1.97)	6.6 (0.26)	11.0 x 8.0 dp (0.43 x 0.31 dp)	1/4*	10.5 (0.41)	70.6 (2.78)	22.2 (0.88)	50 (2)
17 (0.67)	8 (0.31)	60 (2.36)	9 (0.35)	13.7 x 10.5 dp (0.54 x 0.41 dp)	1/4*	11.5 (0.45)	83.6 (3.29)	22.2 (0.88)	63 (2-1/2)
22 (0.87)	10 (0.39)	77 (3.03)	11 (0.43)	16.8 x 13.5 dp (0.66 x 0.53 dp)	3/8*	14.0 (0.55)	104 (4.09)	27.0 (1.06)	80 (3-1/4)
27 (1.06)	12 (0.47)	94 (3.70)	11 (0.43)	16.8 x 13.5 dp (0.66 x 0.53 dp)	3/8*	18.0 (0.71)	121.9 (4.80)	27.0 (1.06)	100 (4)

Global Series™ Cylinders

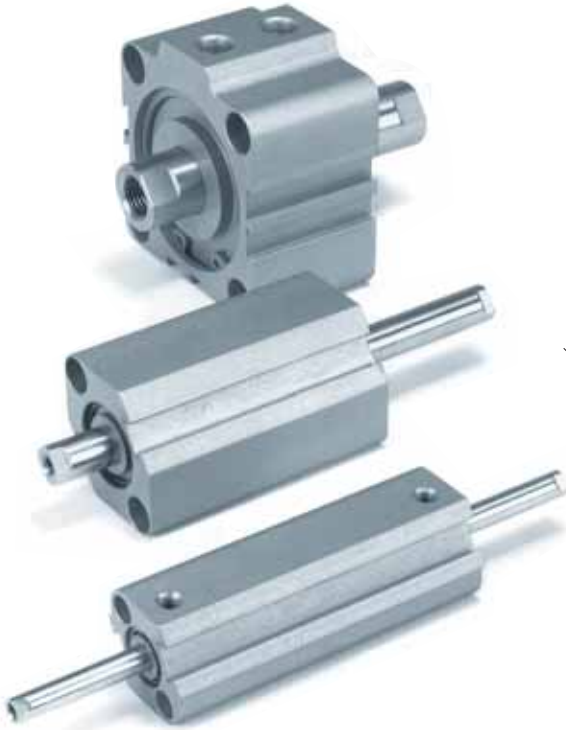

Ø12 - Ø25 mm Bores

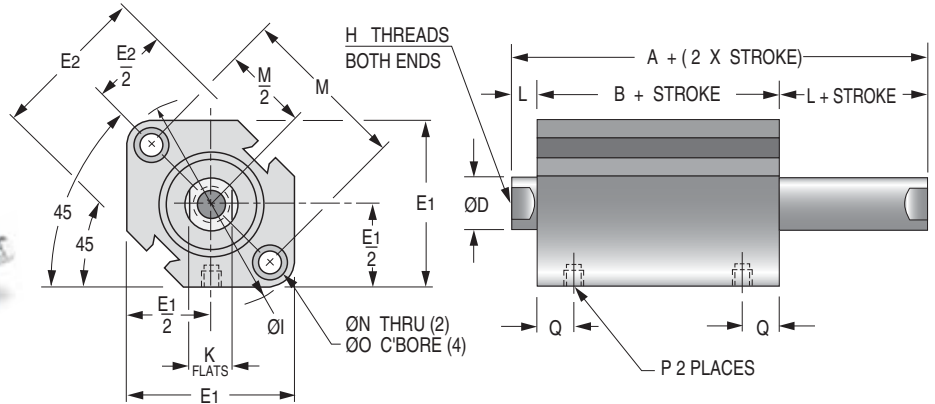

Dimensional Data

Note 1- See page 4 for complete stroke availability
 Note 2- Chart dimensions are shown as mm (inches)

Bore mm	Long Stroke				Extended Stroke				Model Code 'T'	
	Stroke mm	A	B	Q	Stroke mm	A	B	Q	Bore	Hole Size
12	-	-	-	-	50, 75, 100	40.8 (1.61)	33.8 (1.33)	8.9 (.35)	12	NA (NA)
16	-	-	-	-	50, 75, 100	43.2 (1.70)	36.2 (1.42)	10.2 (.40)	16	1.5 (.06)
20	-	-	-	-	75, 100	50.6 (1.99)	41.6 (1.64)	12.1 (.48)	20	1.5 (.06)
25	-	-	-	-	75, 100	57.5 (2.26)	47.5 (1.87)	12.7 (.50)	25	3.1 (.13)
32	75, 100	61.8 (2.43)	47.8 (1.88)	12.7 (.50)	125, 150	61.8 (2.43)	47.8 (1.88)	12.7 (.50)	32	3.1 (.13)
40	75, 100	69.5 (2.74)	55.5 (2.19)	12.7 (.50)	125, 150	69.5 (2.74)	55.5 (2.19)	12.7 (.50)	40	3.1 (.13)
50	75, 100	75.3 (2.96)	59.3 (2.33)	13.2 (.52)	125, 150	75.3 (2.96)	59.3 (2.33)	13.2 (.52)	50	4.0 (.16)
63	75, 100	80.6 (3.17)	64.6 (2.54)	18.5 (.73)	125, 150	80.6 (3.17)	64.6 (2.54)	18.5 (.73)	63	4.0 (.16)
80	75, 100	89.5 (3.52)	69.5 (2.74)	14.0 (.55)	125, 150	89.5 (3.52)	69.5 (2.74)	14.0 (.55)	80	6.3 (.25)
100	75, 100	100.7 (3.96)	76.7 (3.02)	18.0 (.71)	125, 150	100.7 (3.96)	76.7 (3.02)	18.0 (.71)	100	6.3 (.25)

Bore mm (Nom. Inch)	Stroke Range	A	B	ØD	E1	E2	H (Threads) x dp minimum inch or metric	ØI
12 (1/2)	5~30 (0.20~1.18)	32.2 (1.27)	25.2 (0.99)	6 (0.236)	25 (0.98)	23 (0.90)	#8-32 x .21dp M3 x 0.5 - 5 dp	31.5 (1.24)
16 (5/8)	5~30 (0.20~1.18)	33.0 (1.30)	26.0 (1.02)	8 (0.315)	29 (1.14)	27.2 (1.07)	#8-32 x .21dp M4 x 0.7 - 5 dp	37.1 (1.46)
20 (3/4)	5~50 (0.20~2.0)	35.0 (1.38)	26.0 (1.02)	10 (0.394)	36 (1.42)	31.2 (1.23)	#10-32 x .28 dp M5 x 0.8 - 7 dp	47 (1.85)
25 (1)	5~50 (0.20~2.0)	39.0 (1.54)	29.0 (1.14)	12 (0.472)	40 (1.57)	36.9 (1.45)	1/4-28 x .39 dp M6 x 1.0 - 10 dp	51.3 (2.02)
32 (1-1/4)	5 only (0.20)	44.5 (1.75)	30.5 (1.20)	16 (0.630)	44.5 (1.75)	-	5/16-24 x .50 dp M8 x 1.25 - 12 dp	58.9 (2.32)
	10~50 (0.39~2.0)	44.5 (1.75)	30.5 (1.20)	16 (0.630)	44.5 (1.75)	-	5/16-24 x .50 dp M8 x 1.25 - 12 dp	58.9 (2.32)
40 (1-1/2)	5~50 (0.20~2.0)	54.0 (2.13)	40.0 (1.57)	16 (0.630)	52 (2.05)	-	3/8-24 x .50 dp M8 x 1.25 - 12 dp	69 (2.72)
50 (2)	10~50 (0.39~2.0)	56.5 (2.22)	40.5 (1.59)	20 (0.787)	63.7 (2.51)	-	1/2-20 x .50 dp M10 x 1.5 - 12 dp	84.9 (3.34)
63 (2-1/2)	10~50 (0.39~2.0)	58.0 (2.28)	42.0 (1.65)	20 (0.787)	76.7 (3.02)	-	1/2-20 x .50 dp M10 x 1.5 - 12 dp	101.8 (4.01)
80 (3-1/4)	10~50 (0.39~2.0)	71.0 (2.80)	51.0 (2.01)	25 (0.984)	97.8 (3.85)	-	5/8-18 x .88 dp M16 x 2.0 - 22 dp	129.8 (5.11)
100 (4)	10~50 (0.39~2.0)	84.5 (3.33)	60.5 (2.38)	30 (1.181)	115.3 (4.54)	-	3/4-16 x .88 dp M20 x 2.5 - 22 dp	153.9 (6.06)

Double Acting, Double Rod Models

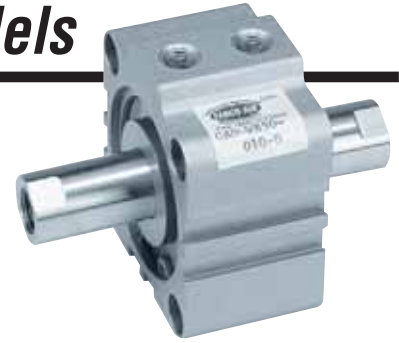

Ø32 - Ø100 mm Bores

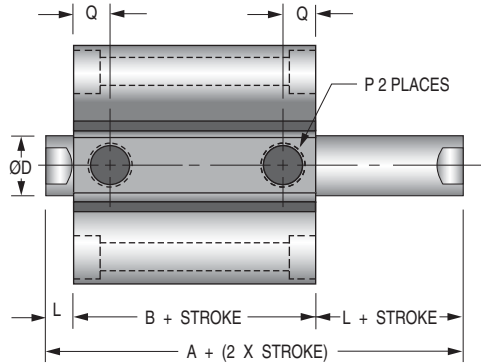
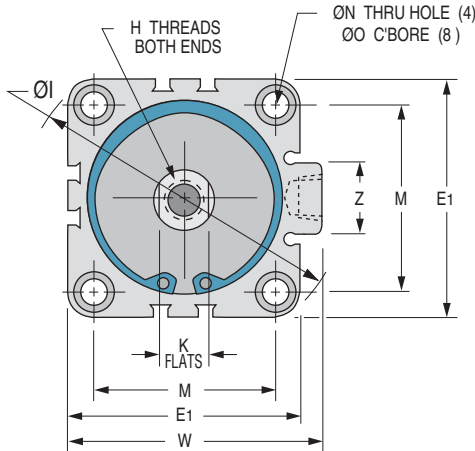

* Port Size Offerings

See dim. column "P" below

- N**– NPT ports, inch rod thread
 - G**– BSP parallel ports, metric rod thread
 - P**– BSPT taper ports, metric rod thread
- Note: M5 x 0.8 port will accept #10-32 male thread fittings.

Note: Inch threads for 'N' port code.
Metric threads for 'G' & 'P' port codes.
Metric for foot, flange, or clevis mount.

Rod end male thread

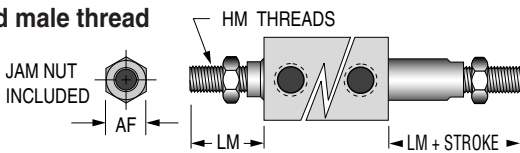

Bore mm	AF (HEX) inch or mm	HM (THREADS) inch or metric	LM inch or mm
12	.34 or 8	#8-32 x .31 lg or M5 x 0.8 - 9 lg	0.45 or 14.0
16	.34 or 10	#8-32 x .31 lg or M6 x 1.0 - 10 lg	0.45 or 15.5
20	.38 or 13	#10-32 x .31 lg or M8 x 1.25 - 12 lg	0.49 or 18.5
25	.43 or 17	1/4-28 x .37 lg or M10 x 1.25 - 15 lg	0.57 or 22.5
32	.50 or 22	5/16-24 x .50 lg or M14 x 1.5 - 20.5 lg	0.78 or 28.5
40	.56 or 22	3/8-24 x .63 lg or M14 x 1.5 - 20.5 lg	0.91 or 28.5
50	.75 or 27	1/2-20 x .77 lg or M18 x 1.5 - 26 lg	1.08 or 33.5
63	.75 or 27	1/2-20 x .77 lg or M18 x 1.5 - 26 lg	1.08 or 33.5
80	.93 or 32	5/8-18 x 1.00 lg or M22 x 1.5 - 32.5 lg	1.40 or 43.5
100	1.13 or 46	3/4-16 x 1.12 lg or M26 x 1.5 - 32.5 lg	1.59 or 43.5

Tapped hole mounting

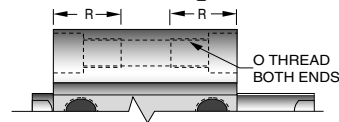

Bore mm	O (THREADS) inch or metric	R inch or mm
12	#8-32 or M4 x 0.7	0.43 or 11
16	#8-32 or M4 x 0.7	0.43 or 11
20	1/4-20 or M6 x 1.0	0.67 or 17
25	1/4-20 or M6 x 1.0	0.67 or 17
32	1/4-20 or M6 x 1.0	0.67 or 17
40	1/4-20 or M6 x 1.0	0.75 or 19
50	5/16-18 or M8 x 1.25	0.75 or 19
63	7/16-14 or M10 x 1.5	0.87 or 22
80	1/2-13 or M12 x 1.75	1.13 or 29
100	1/2-13 or M12 x 1.75	1.13 or 29

K	L	M	ØN	ØO	*P	Q	W	Z	Bore mm (Nom. Inch)
5 (0.20)	3.5 (0.14)	22 (0.87)	3.5 (0.14)	6.5 x 3.5 dp (0.26 x 0.14 dp)	M5x0.8	7.0 (0.28)	-	-	12 (1/2)
6 (0.24)	3.5 (0.14)	28 (1.10)	3.5 (0.14)	6.5 x 3.5 dp (0.26 x 0.14 dp)	M5x0.8	7.8 (0.31)	-	-	16 (5/8)
8 (0.31)	4.5 (0.18)	36 (1.42)	5.5 (0.22)	9.0 x 7.0 dp (0.35 x 0.28 dp)	M5x0.8	8.1 (0.32)	-	-	20 (3/4)
10 (0.39)	5 (0.20)	40 (1.57)	5.5 (0.22)	9.0 x 7.0 dp (0.35 x 0.28 dp)	M5x0.8	8.4 (0.33)	-	-	25 (1)
14 (0.55)	7 (0.28)	34 (1.34)	5.5 (0.22)	9.0 x 7.0 dp (0.35 x 0.28 dp)	M5x0.8	8.7 (0.34)	49.3 (1.94)	16.5 (0.65)	32 (1-1/4)
14 (0.55)	7 (0.28)	34 (1.34)	5.5 (0.22)	9.0 x 7.0 dp (0.35 x 0.28 dp)	1/8*	8.7 (0.34)	49.3 (1.94)	16.5 (0.65)	
14 (0.55)	7 (0.28)	40 (1.57)	5.5 (0.22)	9.0 x 7.0 dp (0.35 x 0.28 dp)	1/8*	9.2 (0.36)	57.0 (2.24)	17.8 (0.70)	40 (1-1/2)
17 (0.67)	8 (0.31)	50 (1.97)	6.6 (0.26)	11.0 x 8.0 dp (0.43 x 0.31 dp)	1/4*	10.5 (0.41)	70.6 (2.78)	22.2 (0.88)	50 (2)
17 (0.67)	8 (0.31)	60 (2.36)	9 (0.35)	13.7 x 10.5 dp (0.54 x 0.41 dp)	1/4*	11.5 (0.45)	83.6 (3.29)	22.2 (0.88)	63 (2-1/2)
22 (0.87)	10 (0.39)	77 (3.03)	11 (0.43)	16.8 x 13.5 dp (0.66 x 0.53 dp)	3/8*	14.0 (0.55)	104 (4.09)	27.0 (1.06)	80 (3-1/4)
27 (1.06)	12 (0.47)	94 (3.70)	11 (0.43)	16.8 x 13.5 dp (0.66 x 0.53 dp)	3/8*	18.0 (0.71)	121.9 (4.80)	27.0 (1.06)	100 (4)

Global Series™ Cylinders



Ø12 - Ø25 mm Bores

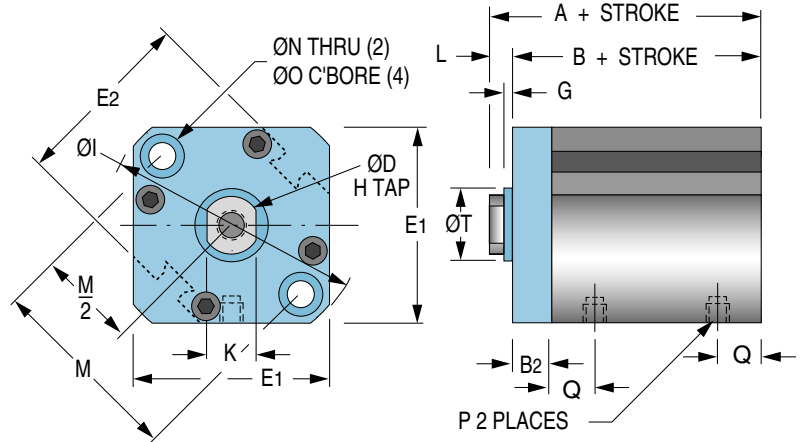

Rod flats (Dim. K)
nominally in-line
with ports

Bore mm	B2
12	5 (.20)
16	5 (.20)
20	8 (.32)
25	8 (.32)

Warning

THIS CYLINDER HAS A NON-ROTATING ROD. TO PREVENT INTERNAL DAMAGE HOLD ROD BY FLATS ONLY WHEN FULLY RETRACTED WHILE INSTALLING OR REMOVING ATTACHMENTS. DO NOT SCRATCH OR DENT SHAFT.

Dimensional Data

Note 1- See page 4 for complete stroke availability

Note 2- Chart dimensions are shown as mm (inches)

Bore size	12	16	20	25	32	40	50	63	80	100
Nonrotating rod accuracy	±2°	±1°	±1°	±1°	±0.8°	±0.8°	±0.8°	±0.8°	±0.8°	±0.8°

Bore mm	Long Stroke				Extended Stroke			
	Stroke mm	A	B	Q	Stroke mm	A	B	Q
12	-	-	-	-	50, 75, 100	42.3 (1.67)	38.8 (1.53)	8.9 (.35)
16	-	-	-	-	50, 75, 100	44.7 (1.76)	41.2 (1.62)	10.2 (.40)
20	-	-	-	-	75, 100	54.1 (2.13)	49.6 (1.95)	12.1 (.48)
25	-	-	-	-	75, 100	60.5 (2.38)	55.5 (2.19)	12.7 (.50)
32	75, 100	49.0 (1.93)	42.0 (1.65)	8.7 (.34)	125, 150	63.8 (2.51)	56.8 (2.24)	12.7 (.50)
40	75, 100	46.5 (1.83)	39.5 (1.56)	9.2 (.36)	125, 150	62.5 (2.46)	55.5 (2.19)	12.7 (.50)
50	75, 100	48.5 (1.91)	40.5 (1.59)	10.5 (.41)	125, 150	67.3 (2.65)	59.3 (2.33)	13.2 (.52)
63	75, 100	54.0 (2.13)	46.0 (1.81)	11.5 (.45)	125, 150	72.6 (2.86)	64.6 (2.54)	18.5 (.73)
80	75, 100	63.5 (2.50)	53.5 (2.11)	14.0 (.55)	125, 150	79.5 (3.13)	69.5 (2.74)	14.0 (.55)
100	75, 100	75.0 (2.95)	63.0 (2.48)	18.0 (.71)	125, 150	88.7 (3.49)	76.7 (3.02)	18.0 (.71)

* Port Size Offerings

See dim. column "P" below

N- NPT ports, inch rod thread
 G- BSP parallel ports, metric rod thread
 P- BSPT taper ports, metric rod thread
 Note: M5 x 0.8 port will accept #10-32 male thread fittings.

Bore mm (Nom. Inch)	Stroke Range	A	B	ØD	E1	E2	H (Threads) x dp minimum inch or metric	ØI
12 (1/2)	5~30 (0.20~1.18)	25.5 (1.00)	22.0 (0.87)	6 (0.236)	25 (0.98)	23 (0.90)	#8-32 x .21dp M3 x 0.5 - 5 dp	31.5 (1.24)
16 (5/8)	5~30 (0.20~1.18)	27.0 (1.06)	23.5 (0.93)	8 (0.315)	29 (1.14)	27.2 (1.07)	#8-32 x .21dp M4 x 0.7 - 5 dp	37.1 (1.46)
20 (3/4)	5~50 (0.20~2.0)	32.0 (1.26)	27.5 (1.08)	10 (0.394)	36 (1.42)	31.2 (1.23)	#10-32 x .28 dp M5 x 0.8 - 7 dp	47 (1.85)
25 (1)	5~50 (0.20~2.0)	35.5 (1.40)	30.5 (1.20)	12 (0.472)	40 (1.57)	36.9 (1.45)	1/4-28 x .39 dp M6 x 1.0 - 10 dp	51.3 (2.02)
32 (1-1/4)	5 only (0.20)	39.0 (1.54)	32.0 (1.26)	16 (0.630)	44.5 (1.75)	-	5/16-24 x .50 dp M8 x 1.25 - 12 dp	58.9 (2.32)
	10~50 (0.39~2.0)	39.0 (1.54)	32.0 (1.26)	16 (0.630)	44.5 (1.75)	-	5/16-24 x .50 dp M8 x 1.25 - 12 dp	58.9 (2.32)
40 (1-1/2)	5~50 (0.20~2.0)	36.5 (1.44)	29.5 (1.16)	16 (0.630)	52 (2.05)	-	3/8-24 x .50 dp M8 x 1.25 - 12 dp	69 (2.72)
50 (2)	10~50 (0.39~2.0)	38.5 (1.52)	30.5 (1.20)	20 (0.787)	63.7 (2.51)	-	1/2-20 x .50 dp M10 x 1.5 - 12 dp	84.9 (3.34)
63 (2-1/2)	10~50 (0.39~2.0)	44.0 (1.73)	36.0 (1.42)	20 (0.787)	76.7 (3.02)	-	1/2-20 x .50 dp M10 x 1.5 - 12 dp	101.8 (4.01)
80 (3-1/4)	10~50 (0.39~2.0)	53.5 (2.11)	43.5 (1.71)	25 (0.984)	97.8 (3.85)	-	5/8-18 x .88 dp M16 x 2.0 - 22 dp	129.8 (5.11)
100 (4)	10~50 (0.39~2.0)	65.0 (2.56)	53.0 (2.09)	30 (1.181)	115.3 (4.54)	-	3/4-16 x .88 dp M20 x 2.5 - 22 dp	153.9 (6.06)

Double Acting, Nonrotating Piston Rod Models

Ø32 mm Bore

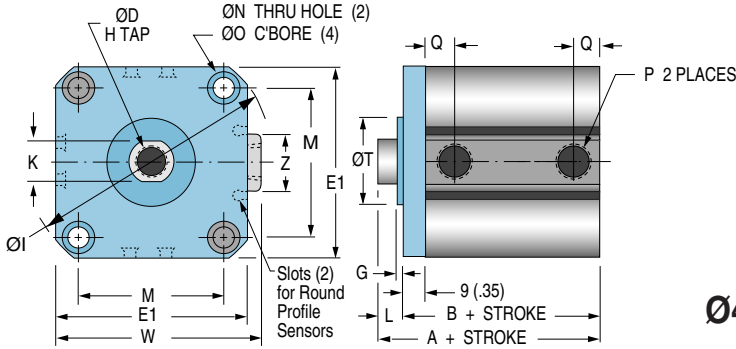

Ø40 - Ø100 mm Bores

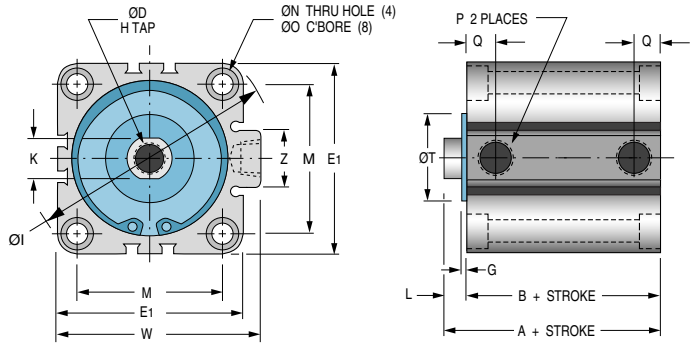

Rod flats (Dim. K) nominally in-line with ports

Bore mm (Nom. Inch)	ØT	G
12 (1/2)	15 +0/- 0.043 (0.591 +0/-0.002)	1.5 (0.059)
16 (5/8)	20 +0/- 0.052 (0.787 +0/-0.002)	1.5 (0.059)
20 (3/4)	13 +0/- 0.043 (0.512 +0/-0.002)	2.0 (0.079)
25 (1)	15 +0/- 0.043 (0.591 +0/-0.002)	2.0 (0.079)
32 (1-1/4)	21 +0/- 0.062 (0.827 +0/-0.002)	2.0 (0.079)
40 (1-1/2)	28 +0/- 0.062 (1.102 +0/-0.002)	2.0 (0.079)
50 (2)	35 +0/- 0.062 (1.378 +0/-0.002)	2.0 (0.079)
63 (2-1/2)	35 +0/- 0.062 (1.378 +0/-0.002)	2.0 (0.079)
80 (3-1/4)	43 +0/- 0.062 (1.693 +0/-0.002)	2.0 (0.079)
100 (4)	59 +0/- 0.074 (2.323 +0/-0.003)	2.0 (0.079)

Rod end male thread

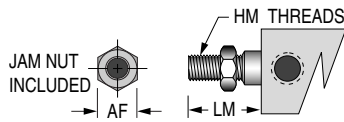

Bore mm	HM (THREADS) inch or metric	LM inch or mm
12	#8-32 x .31 lg or M5 x 0.8 - 9 lg	0.45 or 14.0
16	#8-32 x .31 lg or M6 x 1.0 - 10 lg	0.45 or 15.5
20	#10-32 x .31 lg or M8 x 1.25 - 12 lg	0.49 or 18.5
25	1/4-28 x .37 lg or M10 x 1.25 - 15 lg	0.57 or 22.5
32	5/16-24 x .50 lg or M14 x 1.5 - 20.5 lg	0.78 or 28.5
40	3/8-24 x .63 lg or M14 x 1.5 - 20.5 lg	0.91 or 28.5
50	1/2-20 x .77 lg or M18 x 1.5 - 26 lg	1.08 or 33.5
63	1/2-20 x .77 lg or M18 x 1.5 - 26 lg	1.08 or 33.5
80	5/8-18 x 1.00 lg or M22 x 1.5 - 32.5 lg	1.40 or 43.5
100	3/4-16 x 1.12 lg or M26 x 1.5 - 32.5 lg	1.59 or 43.5

Tapped hole mounting

Note: Inch threads for 'N' port code.
Metric threads for 'G' & 'P' port codes. Metric for foot, flange, or clevis mount.

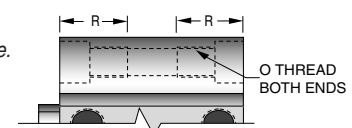

Bore mm	O (THREADS) inch or metric	Places		RF inch or mm	Places		RR inch or mm
		Front	Rear		Front	Rear	
12	#8-32 or M4 x 0.7	2	2	0.63 or 16	2	0.43 or 11	
16	#8-32 or M4 x 0.7	2	2	0.63 or 16	2	0.43 or 11	
20	1/4-20 or M6 x 1.0	2	2	0.98 or 25	2	0.67 or 17	
25	1/4-20 or M6 x 1.0	2	2	0.98 or 25	2	0.67 or 17	
32	1/4-20 or M6 x 1.0	2	4	1.02 or 26	4	0.67 or 17	
40	1/4-20 or M6 x 1.0	4	4	0.75 or 19	4	0.75 or 19	
50	5/16-18 or M8 x 1.25	4	4	0.75 or 19	4	0.75 or 19	
63	7/16-14 or M10 x 1.5	4	4	0.87 or 22	4	0.87 or 22	
80	1/2-13 or M12 x 1.75	4	4	1.13 or 29	4	1.13 or 29	
100	1/2-13 or M12 x 1.75	4	4	1.13 or 29	4	1.13 or 29	

K	L	M	ØN	ØO	*P	Q	W	Z	Bore mm (Nom. Inch)
5.2 (0.20)	3.5 (0.14)	22 (0.87)	3.5 (0.14)	6.5 x 3.5 dp (0.26 x 0.14 dp)	M5x0.8	7.0 (0.28)	-	-	12 (1/2)
6 (0.24)	3.5 (0.14)	28 (1.10)	3.5 (0.14)	6.5 x 3.5 dp (0.26 x 0.14 dp)	M5x0.8	7.8 (0.31)	-	-	16 (5/8)
8 (0.31)	4.5 (0.18)	36 (1.42)	5.5 (0.22)	9.0 x 7.0 dp (0.35 x 0.28 dp)	M5x0.8	8.1 (0.32)	-	-	20 (3/4)
10 (0.39)	5 (0.20)	40 (1.57)	5.5 (0.22)	9.0 x 7.0 dp (0.35 x 0.28 dp)	M5x0.8	8.4 (0.33)	-	-	25 (1)
14 (0.55)	7 (0.28)	34 (1.34)	5.5 (0.22)	9.0 x 7.0 dp (0.35 x 0.28 dp)	M5x0.8	8.7 (0.34)	49.3 (1.94)	16.5 (0.65)	32 (1-1/4)
14 (0.55)	7 (0.28)	34 (1.34)	5.5 (0.22)	9.0 x 7.0 dp (0.35 x 0.28 dp)	1/8*	8.7 (0.34)	49.3 (1.94)	16.5 (0.65)	32 (1-1/4)
14 (0.55)	7 (0.28)	40 (1.57)	5.5 (0.22)	9.0 x 7.0 dp (0.35 x 0.28 dp)	1/8*	9.2 (0.36)	57.0 (2.24)	17.8 (0.70)	40 (1-1/2)
18 (0.71)	8 (0.31)	50 (1.97)	6.6 (0.26)	11.0 x 8.0 dp (0.43 x 0.31 dp)	1/4*	10.5 (0.41)	70.6 (2.78)	22.2 (0.88)	50 (2)
18 (0.71)	8 (0.31)	60 (2.36)	9 (0.35)	13.7 x 10.5 dp (0.54 x 0.41 dp)	1/4*	11.5 (0.45)	83.6 (3.29)	22.2 (0.88)	63 (2-1/2)
22 (0.87)	10 (0.39)	77 (3.03)	11 (0.43)	16.8 x 13.5 dp (0.66 x 0.53 dp)	3/8*	14.0 (0.55)	104 (4.09)	27.0 (1.06)	80 (3-1/4)
27 (1.06)	12 (0.47)	94 (3.70)	11 (0.43)	16.8 x 13.5 dp (0.66 x 0.53 dp)	3/8*	18.0 (0.71)	121.9 (4.80)	27.0 (1.06)	100 (4)

Global Series™ Cylinders



Ø12 - Ø25 mm Bores

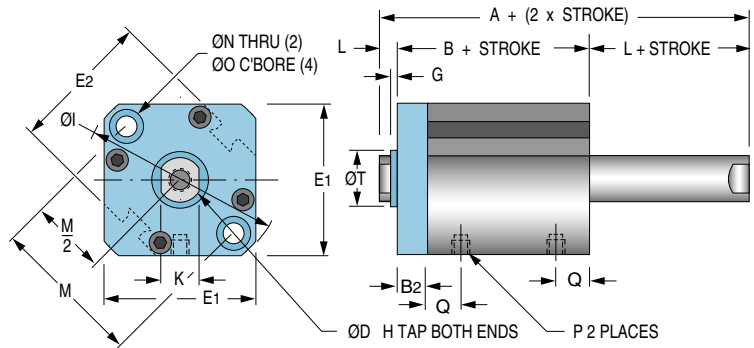

Warning

THIS CYLINDER HAS A NON-ROTATING ROD. TO PREVENT INTERNAL DAMAGE HOLD ROD BY FLATS ONLY WHEN FULLY RETRACTED WHILE INSTALLING OR REMOVING ATTACHMENTS. DO NOT SCRATCH OR DENT SHAFT.

Rod flats (Dim. K) nominally in-line with ports

Bore mm	B2
12	5 (.20)
16	5 (.20)
20	8 (.32)
25	8 (.32)

Dimensional Data

Note 1- See page 4 for complete stroke availability

Note 2- Chart dimensions are shown as mm (inches)

Bore size	12	16	20	25	32	40	50	63	80	100
Nonrotating rod accuracy	±2°	±1°	±1°	±1°	±0.8°	±0.8°	±0.8°	±0.8°	±0.8°	±0.8°

Bore mm	Long Stroke				Extended Stroke			
	Stroke mm	A	B	Q	Stroke mm	A	B	Q
12	-	-	-	-	50, 75, 100	45.8 (1.80)	38.8 (1.53)	8.9 (.35)
16	-	-	-	-	50, 75, 100	48.2 (1.90)	41.2 (1.62)	10.2 (.40)
20	-	-	-	-	75, 100	58.6 (2.31)	49.6 (1.95)	12.1 (.48)
25	-	-	-	-	75, 100	65.5 (2.58)	55.5 (2.19)	12.7 (.50)
32	75, 100	70.8 (2.79)	56.8 (2.24)	12.7 (.50)	125, 150	70.8 (2.79)	56.8 (2.24)	12.7 (.50)
40	75, 100	69.5 (2.74)	55.5 (2.19)	12.7 (.50)	125, 150	69.5 (2.74)	55.5 (2.19)	12.7 (.50)
50	75, 100	75.3 (2.96)	59.3 (2.33)	13.2 (.52)	125, 150	75.3 (2.96)	59.3 (2.33)	13.2 (.52)
63	75, 100	80.6 (3.17)	64.6 (2.54)	18.5 (.73)	125, 150	80.6 (3.17)	64.6 (2.54)	18.5 (.73)
80	75, 100	89.5 (3.52)	69.5 (2.74)	14.0 (.55)	125, 150	89.5 (3.52)	69.5 (2.74)	14.0 (.55)
100	75, 100	100.7 (3.96)	76.7 (3.02)	18.0 (.71)	125, 150	100.7 (3.96)	76.7 (3.02)	18.0 (.71)

Model Code 'M'	
Bore	Hole Size
12	NA (NA)
16	1.5 (.06)
20	1.5 (.06)
25	3.1 (.13)
32	3.1 (.13)
40	3.1 (.13)
50	4.0 (.16)
63	4.0 (.16)
80	6.3 (.25)
100	6.3 (.25)

Bore mm (Nom. Inch)	Stroke Range	A	B	ØD	E1	E2	H (Threads) x dp minimum inch or metric	ØI
12 (1/2)	5-30 (0.20~1.18)	37.2 (1.46)	30.2 (1.19)	6 (0.236)	25 (0.98)	23 (0.90)	#8-32 x .21dp M3 x 0.5 - 5 dp	31.5 (1.24)
16 (5/8)	5-30 (0.20~1.18)	38.0 (1.50)	31.0 (1.22)	8 (0.315)	29 (1.14)	27.2 (1.07)	#8-32 x .21dp M4 x 0.7 - 5 dp	37.1 (1.46)
20 (3/4)	5-50 (0.20~2.0)	43.0 (1.69)	34.0 (1.34)	10 (0.394)	36 (1.42)	31.2 (1.23)	#10-32 x .28 dp M5 x 0.8 - 7 dp	47 (1.85)
25 (1)	5-50 (0.20~2.0)	47.0 (1.85)	37.0 (1.46)	12 (0.472)	40 (1.57)	36.9 (1.45)	1/4-28 x .39 dp M6 x 1.0 - 10 dp	51.3 (2.02)
32 (1-1/4)	5 only (0.20)	53.5 (2.11)	39.5 (1.56)	16 (0.630)	44.5 (1.75)	-	5/16-24 x .50 dp M8 x 1.25 - 12 dp	58.9 (2.32)
	10-50 (0.39~2.0)	53.5 (2.11)	39.5 (1.56)	16 (0.630)	44.5 (1.75)	-	5/16-24 x .50 dp M8 x 1.25 - 12 dp	58.9 (2.32)
40 (1-1/2)	5-50 (0.20~2.0)	54.0 (2.13)	40.0 (1.57)	16 (0.630)	52 (2.05)	-	3/8-24 x .50 dp M8 x 1.25 - 12 dp	69 (2.72)
50 (2)	10-50 (0.39~2.0)	56.5 (2.22)	40.5 (1.59)	20 (0.787)	63.7 (2.51)	-	1/2-20 x .50 dp M10 x 1.5 - 12 dp	84.9 (3.34)
63 (2-1/2)	10-50 (0.39~2.0)	58.0 (2.28)	42.0 (1.65)	20 (0.787)	76.7 (3.02)	-	1/2-20 x .50 dp M10 x 1.5 - 12 dp	101.8 (4.01)
80 (3-1/4)	10-50 (0.39~2.0)	71.0 (2.80)	51.0 (2.01)	25 (0.984)	97.8 (3.85)	-	5/8-18 x .88 dp M16 x 2.0 - 22 dp	129.8 (5.11)
100 (4)	10-50 (0.39~2.0)	84.5 (3.33)	60.5 (2.38)	30 (1.181)	115.3 (4.54)	-	3/4-16 x .88 dp M20 x 2.5 - 22 dp	153.9 (6.06)

Double Acting, Double Rod, Nonrotating Piston Rod Models

Ø32 mm Bore

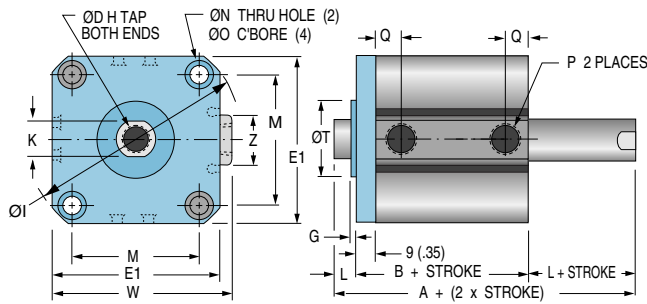

Bore mm (Nom. Inch)	ØT		G
12 (1/2)	15 +0/- 0.043	(0.591 +0/-0.002)	1.5 (0.059)
16 (5/8)	20 +0/- 0.052	(0.787 +0/-0.002)	1.5 (0.059)
20 (3/4)	13 +0/- 0.043	(0.512 +0/-0.002)	2.0 (0.079)
25 (1)	15 +0/- 0.043	(0.591 +0/-0.002)	2.0 (0.079)
32 (1-1/4)	21 +0/- 0.062	(0.827 +0/-0.002)	2.0 (0.079)
40 (1-1/2)	28 +0/- 0.062	(1.102 +0/-0.002)	2.0 (0.079)
50 (2)	35 +0/- 0.062	(1.378 +0/-0.002)	2.0 (0.079)
63 (2-1/2)	35 +0/- 0.062	(1.378 +0/-0.002)	2.0 (0.079)
80 (3-1/4)	43 +0/- 0.062	(1.693 +0/-0.002)	2.0 (0.079)
100 (4)	59 +0/- 0.074	(2.323 +0/-0.003)	2.0 (0.079)

Ø40 - Ø100 mm Bores

Rod flats (Dim. K) nominally in-line with ports

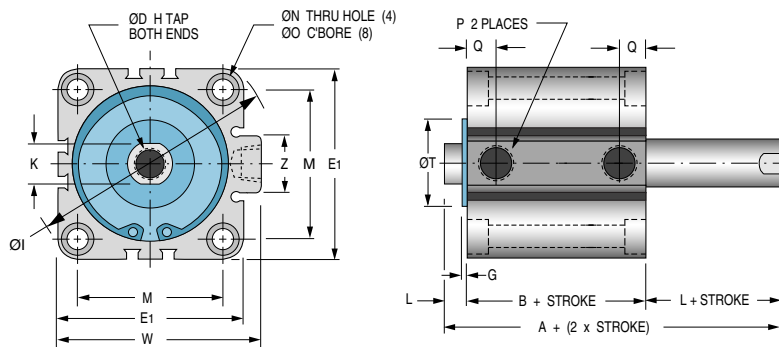

*** Port Size Offerings**
See dim. column "P" below

- N**- NPT ports, inch rod thread
- G**- BSP parallel ports, metric rod thread
- P**- BSPT taper ports, metric rod thread

Note: M5 x 0.8 port will accept #10-32 male thread fittings.

Rod end male thread

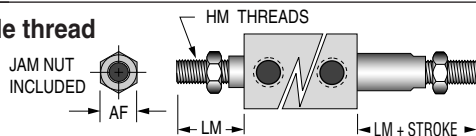

Bore mm	AF (HEX) inch or mm	HM (THREADS) inch or metric	LM inch or mm
12	.34 or 8	#8-32 x .31 lg or M5 x 0.8 - 9 lg	0.45 or 14.0
16	.38 or 10	#8-32 x .31 lg or M6 x 1.0 - 10 lg	0.45 or 15.5
20	.38 or 13	#10-32 x .31 lg or M8 x 1.25 - 12 lg	0.49 or 18.5
25	.43 or 17	1/4-28 x .37 lg or M10 x 1.25 - 15 lg	0.57 or 22.5
32	.50 or 22	5/16-24 x .50 lg or M14 x 1.5 - 20.5 lg	0.78 or 28.5
40	.56 or 22	3/8-24 x .63 lg or M14 x 1.5 - 20.5 lg	0.91 or 28.5
50	.75 or 27	1/2-20 x .77 lg or M18 x 1.5 - 26 lg	1.08 or 33.5
63	.75 or 27	1/2-20 x .77 lg or M18 x 1.5 - 26 lg	1.08 or 33.5
80	.93 or 32	5/8-18 x 1.00 lg or M22 x 1.5 - 32.5 lg	1.40 or 43.5
100	1.13 or 46	3/4-16 x 1.12 lg or M26 x 1.5 - 32.5 lg	1.59 or 43.5

Tapped hole mounting

Note: Inch threads for 'N' port cod
Metric threads for 'G' & 'P' port codes. Metric for foot, flange, or clevis mount.

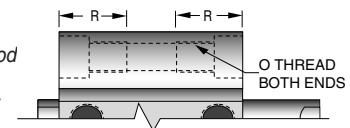

Bore mm	O (THREADS) inch or metric	Places Front	RF		RR	
			inch or mm	inch or mm	inch or mm	inch or mm
12	#8-32 or M4 x 0.7	2	0.63 or 16	2	0.43 or 11	
16	#8-32 or M4 x 0.7	2	0.63 or 16	2	0.43 or 11	
20	1/4-20 or M6 x 1.0	2	0.98 or 25	2	0.67 or 17	
25	1/4-20 or M6 x 1.0	2	0.98 or 25	2	0.67 or 17	
32	1/4-20 or M6 x 1.0	2	1.02 or 26	4	0.67 or 17	
40	1/4-20 or M6 x 1.0	4	0.75 or 19	4	0.75 or 19	
50	5/16-18 or M8 x 1.25	4	0.75 or 19	4	0.75 or 19	
63	7/16-14 or M10 x 1.5	4	0.87 or 22	4	0.87 or 22	
80	1/2-13 or M12 x 1.75	4	1.13 or 29	4	1.13 or 29	
100	1/2-13 or M12 x 1.75	4	1.13 or 29	4	1.13 or 29	

K	L	M	ØN	ØO	*P	Q	W	Z	Bore mm (Nom. Inch)
5.2 (0.20)	3.5 (0.14)	22 (0.87)	3.5 (0.14)	6.5 x 3.5 dp (0.26 x 0.14 dp)	M5x0.8	7.0 (0.28)	-	-	12 (1/2)
6 (0.24)	3.5 (0.14)	28 (1.10)	3.5 (0.14)	6.5 x 3.5 dp (0.26 x 0.14 dp)	M5x0.8	7.8 (0.31)	-	-	16 (5/8)
8 (0.31)	4.5 (0.18)	36 (1.42)	5.5 (0.22)	9.0 x 7.0 dp (0.35 x 0.28 dp)	M5x0.8	8.1 (0.32)	-	-	20 (3/4)
10 (0.39)	5 (0.20)	40 (1.57)	5.5 (0.22)	9.0 x 7.0 dp (0.35 x 0.28 dp)	M5x0.8	8.4 (0.33)	-	-	25 (1)
14 (0.55)	7 (0.28)	34 (1.34)	5.5 (0.22)	9.0 x 7.0 dp (0.35 x 0.28 dp)	M5x0.8	8.7 (0.34)	49.3 (1.94)	16.5 (0.65)	32 (1-1/4)
14 (0.55)	7 (0.28)	34 (1.34)	5.5 (0.22)	9.0 x 7.0 dp (0.35 x 0.28 dp)	1/8*	8.7 (0.34)	49.3 (1.94)	16.5 (0.65)	
14 (0.55)	7 (0.28)	40 (1.57)	5.5 (0.22)	9.0 x 7.0 dp (0.35 x 0.28 dp)	1/8*	9.2 (0.36)	57.0 (2.24)	17.8 (0.70)	40 (1-1/2)
18 (0.71)	8 (0.31)	50 (1.97)	6.6 (0.26)	11.0 x 8.0 dp (0.43 x 0.31 dp)	1/4*	10.5 (0.41)	70.6 (2.78)	22.2 (0.88)	50 (2)
18 (0.71)	8 (0.31)	60 (2.36)	9 (0.35)	13.7 x 10.5 dp (0.54 x 0.41 dp)	1/4*	11.5 (0.45)	83.6 (3.29)	22.2 (0.88)	63 (2-1/2)
22 (0.87)	10 (0.39)	77 (3.03)	11 (0.43)	16.8 x 13.5 dp (0.66 x 0.53 dp)	3/8*	14.0 (0.55)	104 (4.09)	27.0 (1.06)	80 (3-1/4)
27 (1.06)	12 (0.47)	94 (3.70)	11 (0.43)	16.8 x 13.5 dp (0.66 x 0.53 dp)	3/8*	18.0 (0.71)	121.9 (4.80)	27.0 (1.06)	100 (4)

Global Series™ Cylinders

Ø12 - Ø25 mm Bores

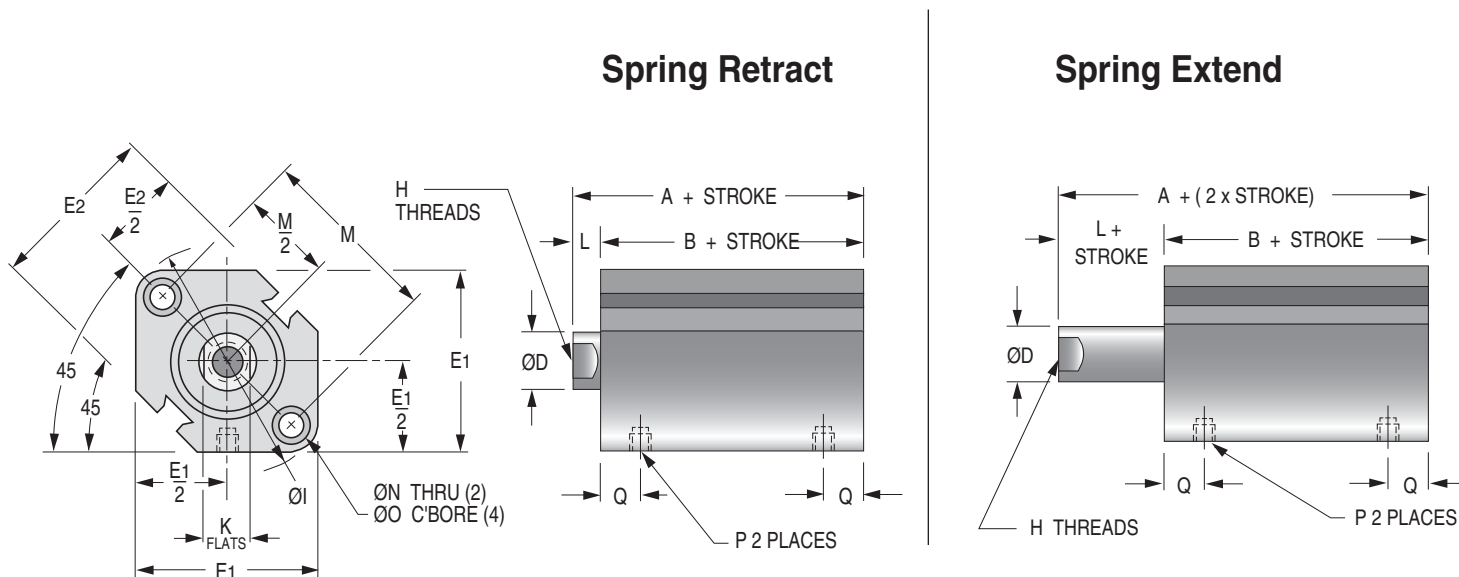

Note 1- See page 4 for complete stroke availability

Note 2- Chart dimensions are shown as mm (inches)

*** Port Size Offerings**
See dim. column "P" below

- N**- NPT ports, inch rod thread
- G**- BSP parallel ports, metric rod thread
- P**- BSPT taper ports, metric rod thread

Note: M5 x 0.8 port will accept #10-32 male thread fittings.

Dimensional Data

Bore mm (Nom. Inch)	Stroke Range	A	B	ØD	E1	E2	H (Threads) x dp minimum inch or metric	Ø1
12 (1/2)	5~10 (0.20~0.39)	20.5 (0.81)	17.0 (0.67)	6 (0.236)	25 (0.98)	23 (0.90)	#8-32 x .21dp M3 x 0.5 - 5 dp	31.5 (1.24)
16 (5/8)	5~10 (0.20~0.39)	22.0 (0.87)	18.5 (0.73)	8 (0.315)	29 (1.14)	27.2 (1.07)	#8-32 x .21dp M4 x 0.7 - 5 dp	37.1 (1.46)
20 (3/4)	5~10 (0.20~0.39)	24.0 (0.94)	19.5 (0.77)	10 (0.394)	36 (1.42)	31.2 (1.23)	#10-32 x .28 dp M5 x 0.8 - 7 dp	47 (1.85)
25 (1)	5~10 (0.20~0.39)	27.5 (1.08)	22.5 (0.86)	12 (0.472)	40 (1.57)	36.9 (1.45)	1/4-28 x .39 dp M6 x 1.0 - 10 dp	51.3 (2.02)
32 (1-1/4)	5 (0.20)	30.0 (1.18)	23.0 (0.91)	16 (0.630)	44.5 (1.75)	-	5/16-24 x .50 dp M8 x 1.25 - 12 dp	58.9 (2.32)
	10 (0.39)	30.0 (1.18)	23.0 (0.91)	16 (0.630)	44.5 (1.75)	-	5/16-24 x .50 dp M8 x 1.25 - 12 dp	58.9 (2.32)
40 (1-1/2)	5~10 (0.20~0.39)	36.5 (1.44)	29.5 (1.16)	16 (0.630)	52 (2.05)	-	3/8-24 x .50 dp M8 x 1.25 - 12 dp	69 (2.72)
50 (2)	10~20 (0.39~0.79)	38.5 (1.52)	30.5 (1.20)	20 (0.787)	63.7 (2.51)	-	1/2-20 x .50 dp M10 x 1.5 - 12 dp	84.9 (3.34)

Single Acting, Spring Retract/Spring Extend Models

Ø32 - Ø50 mm Bores



Spring Retract



Spring Extend

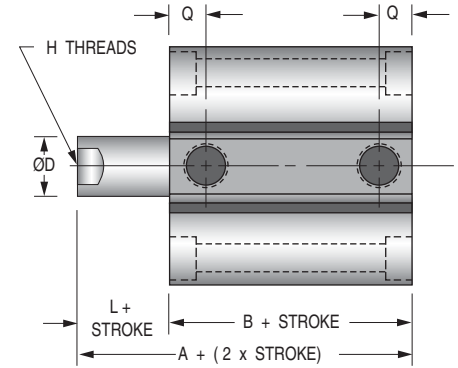
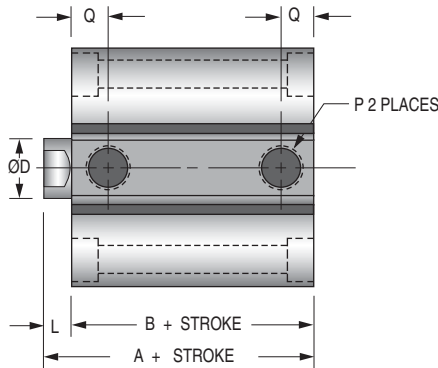
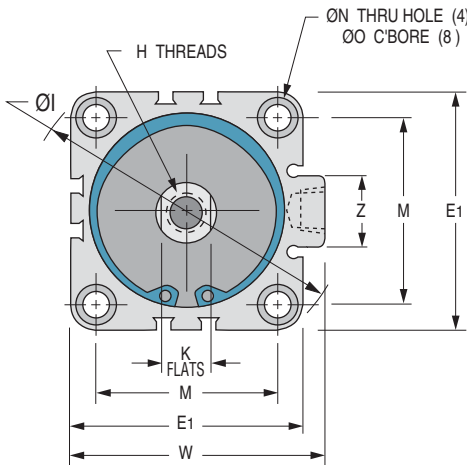

Note: Inch threads for 'N' port code.
Metric threads for 'G' & 'P' port codes.
Metric for foot, flange, or clevis mount.

Rod end male thread

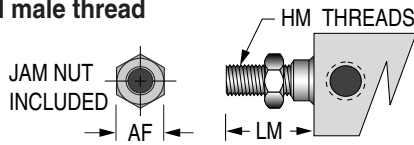

Bore mm	AF (HEX) inch or mm	H M (THREADS) inch or metric	L M Retracted inch or mm
12	.34 or 8	#8-32 x .31 lg or M5 x 0.8 - 9 lg	0.45 or 14.0
16	.34 or 10	#8-32 x .31 lg or M6 x 1.0 - 10 lg	0.45 or 15.5
20	.38 or 13	#10-32 x .31 lg or M8 x 1.25 - 12 lg	0.49 or 18.5
25	.43 or 17	1/4-28 x .37 lg or M10 x 1.25 - 15 lg	0.57 or 22.5
32	.50 or 22	5/16-24 x .50 lg or M14 x 1.5 - 20.5 lg	0.78 or 28.5
40	.56 or 22	3/8-24 x .63 lg or M14 x 1.5 - 20.5 lg	0.91 or 28.5
50	.75 or 27	1/2-20 x .77 lg or M18 x 1.5 - 26 lg	1.08 or 33.5

Tapped hole mounting

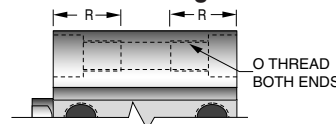

Bore mm	O (THREADS) inch or metric	R inch or mm
12	#8-32 or M4 x 0.7	0.43 or 11
16	#8-32 or M4 x 0.7	0.43 or 11
20	1/4-20 or M6 x 1.0	0.67 or 17
25	1/4-20 or M6 x 1.0	0.67 or 17
32	1/4-20 or M6 x 1.0	0.67 or 17
40	1/4-20 or M6 x 1.0	0.75 or 19
50	5/16-18 or M8 x 1.25	0.75 or 19

K	L	M	ØN	ØO	*P	Q	W	Z	Bore mm (Nom. Inch)
5 (0.20)	3.5 (0.14)	22 (0.87)	3.5 (0.14)	6.5 x 3.5 dp (0.26 x 0.14 dp)	M5x0.8	7.0 (0.28)	-	-	12 (1/2)
6 (0.24)	3.5 (0.14)	28 (1.10)	3.5 (0.14)	6.5 x 3.5 dp (0.26 x 0.14 dp)	M5x0.8	7.8 (0.31)	-	-	16 (5/8)
8 (0.31)	4.5 (0.18)	36 (1.42)	5.5 (0.22)	9.0 x 7.0 dp (0.35 x 0.28 dp)	M5x0.8	8.1 (0.32)	-	-	20 (3/4)
10 (0.39)	5 (0.20)	40 (1.57)	5.5 (0.22)	9.0 x 7.0 dp (0.35 x 0.28 dp)	M5x0.8	8.4 (0.33)	-	-	25 (1)
14 (0.55)	7 (0.28)	34 (1.34)	5.5 (0.22)	9.0 x 7.0 dp (0.35 x 0.28 dp)	M5x0.8	8.7 (0.34)	49.3 (1.94)	16.5 (0.65)	32 (1-1/4)
14 (0.55)	7 (0.28)	34 (1.34)	5.5 (0.22)	9.0 x 7.0 dp (0.35 x 0.28 dp)	1/8*	8.7 (0.34)	49.3 (1.94)	16.5 (0.65)	32 (1-1/4)
14 (0.55)	7 (0.28)	40 (1.57)	5.5 (0.22)	9.0 x 7.0 dp (0.35 x 0.28 dp)	1/8*	9.2 (0.36)	57.0 (2.24)	17.8 (0.70)	40 (1-1/2)
17 (0.67)	8 (0.31)	50 (1.97)	6.6 (0.26)	11.0 x 8.0 dp (0.43 x 0.31 dp)	1/4*	10.5 (0.41)	70.6 (2.78)	22.2 (0.88)	50 (2)

Global Series™ Cylinders

– Magnetic Piston

Ø12 - Ø25 mm Bores

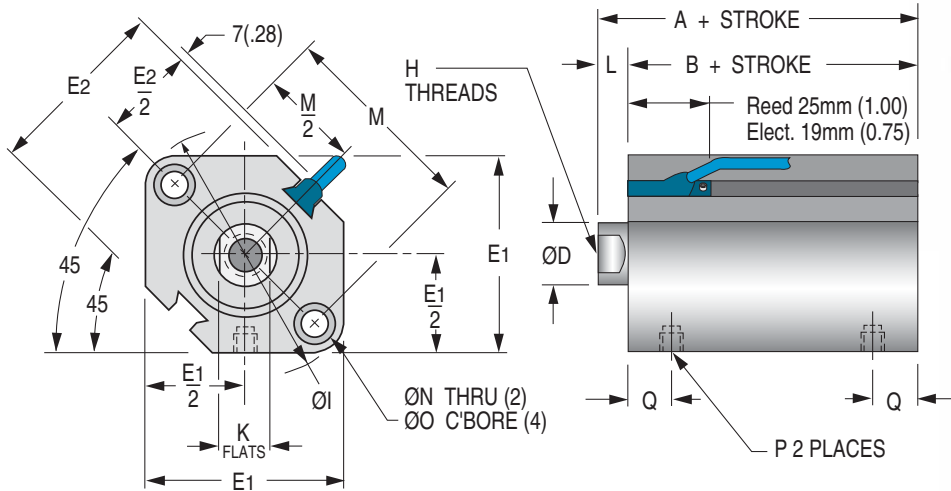

Dimensional Data

Note 1- See page 4 for complete stroke availability
 Note 2- Chart dimensions are shown as mm (inches)

Sensors must be ordered separately. See page 37.

Bore mm	Long Stroke				Extended Stroke			
	Stroke mm	A	B	Q	Stroke mm	A	B	Q
12	–	–	–	–	50, 75, 100	37.3 (1.47)	33.8 (1.33)	8.9 (.35)
16	–	–	–	–	50, 75, 100	39.7 (1.56)	36.2 (1.42)	10.2 (.40)
20	–	–	–	–	75, 100	46.1 (1.82)	41.6 (1.64)	12.1 (.48)
25	–	–	–	–	75, 100	52.5 (2.07)	47.5 (1.87)	12.7 (.50)
32	75, 100	40.0 (1.57)	33.0 (1.30)	8.7 (.34)	125, 150	54.8 (2.16)	47.8 (1.88)	12.7 (.50)
40	75, 100	46.5 (1.83)	39.5 (1.56)	9.2 (.36)	125, 150	62.5 (2.46)	55.5 (2.19)	12.7 (.50)
50	75, 100	48.5 (1.91)	40.5 (1.59)	10.5 (.41)	125, 150	67.3 (2.65)	59.3 (2.33)	13.2 (.52)
63	75, 100	54.0 (2.13)	46.0 (1.81)	11.5 (.45)	125, 150	72.6 (2.86)	64.6 (2.54)	18.5 (.73)
80	75, 100	63.5 (2.50)	53.5 (2.11)	14.0 (.55)	125, 150	79.5 (3.13)	69.5 (2.74)	14.0 (.55)
100	75, 100	75.0 (2.95)	63.0 (2.48)	18.0 (.71)	125, 150	88.7 (3.49)	76.7 (3.02)	18.0 (.71)

*** Port Size Offerings**
 See dim. column "P" below

N– NPT ports, inch rod thread
G– BSP parallel ports, metric rod thread
P– BSPT taper ports, metric rod thread

Note: M5 x 0.8 port will accept #10-32 male thread fittings.

Bore mm (Nom. Inch)	Stroke Range	A	B	ØD	E1	E2	H (Threads) x dp minimum inch or metric	ØI
12 (1/2)	5~30 (0.20~1.18)	31.5 (1.24)	28.0 (1.10)	6 (0.236)	25 (0.98)	23 (0.90)	#8-32 x .21dp M3 x 0.5 – 5 dp	31.5 (1.24)
16 (5/8)	5~30 (0.20~1.18)	34.0 (1.34)	30.5 (1.20)	8 (0.315)	29 (1.14)	27.2 (1.07)	#8-32 x .21dp M4 x 0.7 – 5 dp	37.1 (1.46)
20 (3/4)	5~50 (0.20~2.0)	36.0 (1.42)	31.5 (1.24)	10 (0.394)	36 (1.42)	31.2 (1.23)	#10-32 x .28 dp M5 x 0.8 – 7 dp	47 (1.85)
25 (1)	5~50 (0.20~2.0)	37.5 (1.48)	32.5 (1.28)	12 (0.472)	40 (1.57)	36.9 (1.45)	1/4-28 x .39 dp M6 x 1.0 – 10 dp	51.3 (2.02)
32 (1-1/4)	5~50 (0.20~2.0)	40.0 (1.57)	33.0 (1.30)	16 (0.630)	44.5 (1.75)	–	5/16-24 x .50 dp M8 x 1.25 – 12 dp	58.9 (2.32)
40 (1-1/2)	5~50 (0.20~2.0)	46.5 (1.83)	39.5 (1.56)	16 (0.630)	52 (2.05)	–	3/8-24 x .50 dp M8 x 1.25 – 12 dp	69 (2.72)
50 (2)	10~50 (0.39~2.0)	48.5 (1.91)	40.5 (1.59)	20 (0.787)	63.7 (2.51)	–	1/2-20 x .50 dp M10 x 1.5 – 12 dp	84.9 (3.34)
63 (2-1/2)	10~50 (0.39~2.0)	54.0 (2.13)	46.0 (1.81)	20 (0.787)	76.7 (3.02)	–	1/2-20 x .50 dp M10 x 1.5 – 12 dp	101.8 (4.01)
80 (3-1/4)	10~50 (0.39~2.0)	63.5 (2.50)	53.5 (2.11)	25 (0.984)	97.8 (3.85)	–	5/8-18 x .88 dp M16 x 2.0 – 22 dp	129.8 (5.11)
100 (4)	10~50 (0.39~2.0)	75.0 (2.95)	63.0 (2.48)	30 (1.181)	115.3 (4.54)	–	3/4-16 x .88 dp M20 x 2.5 – 22 dp	153.9 (6.06)

Double Acting, Single Rod Models

Ø32 - Ø100 mm Bores

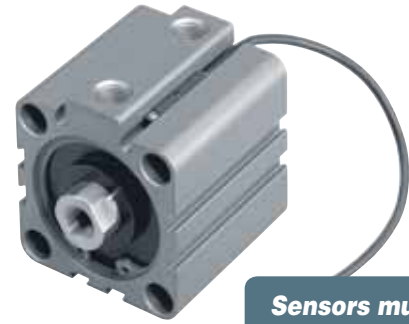

Sensors must be ordered separately. See page 37.

Round Profile Sensor Shown

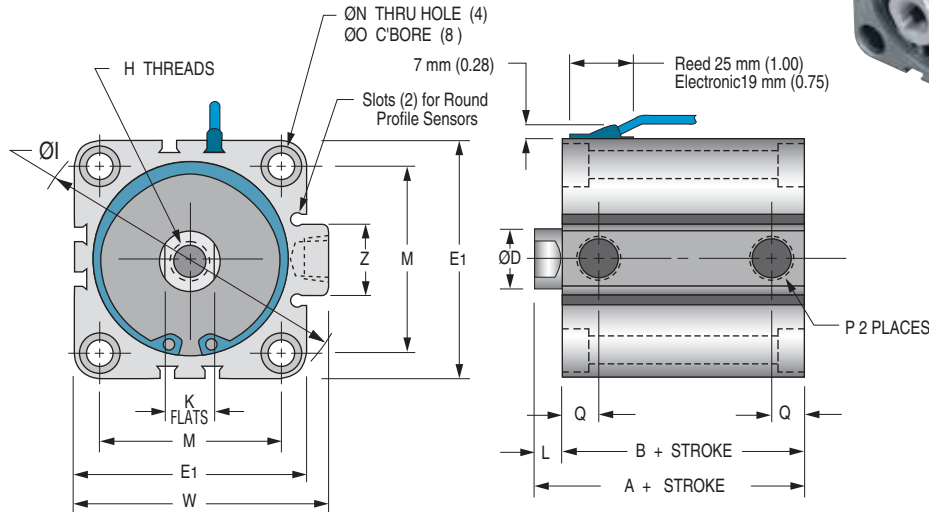

See page 37 for round profile sensors featuring surge suppression, polarity protection and dual output.

Rod end male thread

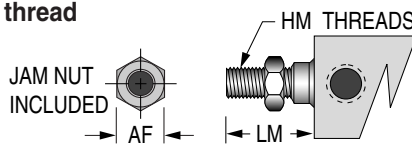

Bore mm	AF (HEX) inch or mm	HM (THREADS) inch or metric	LM inch or mm
12	.34 or 8	#8-32 x .31 lg or M5 x 0.8 - 9 lg	0.45 or 14.0
16	.34 or 10	#8-32 x .31 lg or M6 x 1.0 - 10 lg	0.45 or 15.5
20	.38 or 13	#10-32 x .31 lg or M8 x 1.25 - 12 lg	0.49 or 18.5
25	.43 or 17	1/4-28 x .37 lg or M10 x 1.25 - 15 lg	0.57 or 22.5
32	.50 or 22	5/16-24 x .50 lg or M14 x 1.5 - 20.5 lg	0.78 or 28.5
40	.56 or 22	3/8-24 x .63 lg or M14 x 1.5 - 20.5 lg	0.91 or 28.5
50	.75 or 27	1/2-20 x .77 lg or M18 x 1.5 - 26 lg	1.08 or 33.5
63	.75 or 27	1/2-20 x .77 lg or M18 x 1.5 - 26 lg	1.08 or 33.5
80	.93 or 32	5/8-18 x 1.00 lg or M22 x 1.5 - 32.5 lg	1.40 or 43.5
100	1.13 or 46	3/4-16 x 1.12 lg or M26 x 1.5 - 32.5 lg	1.59 or 43.5

Tapped hole mounting

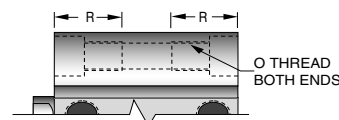

Bore mm	O (THREADS) inch or metric	R inch or mm
12	#8-32 or M4 x 0.7	0.43 or 11
16	#8-32 or M4 x 0.7	0.43 or 11
20	1/4-20 or M6 x 1.0	0.67 or 17
25	1/4-20 or M6 x 1.0	0.67 or 17
32	1/4-20 or M6 x 1.0	0.67 or 17
40	1/4-20 or M6 x 1.0	0.75 or 19
50	5/16-18 or M8 x 1.25	0.75 or 19
63	7/16-14 or M10 x 1.5	0.87 or 22
80	1/2-13 or M12 x 1.75	1.13 or 29
100	1/2-13 or M12 x 1.75	1.13 or 29

Note: Inch threads for 'N' port code. Metric threads for 'G' & 'P' port codes. Metric for foot, flange, or clevis mount.

K	L	M	ØN	ØO	*P	Q	W	Z	Bore mm (Nom. Inch)
5 (0.20)	3.5 (0.14)	22 (0.87)	3.5 (0.14)	6.5 x 3.5 dp (0.26 x 0.14 dp)	M5x0.8	7.0 (0.28)	-	-	12 (1/2)
6 (0.24)	3.5 (0.14)	28 (1.10)	3.5 (0.14)	6.5 x 3.5 dp (0.26 x 0.14 dp)	M5x0.8	7.8 (0.31)	-	-	16 (5/8)
8 (0.31)	4.5 (0.18)	36 (1.42)	5.5 (0.22)	9.0 x 7.0 dp (0.35 x 0.28 dp)	M5x0.8	8.1 (0.32)	-	-	20 (3/4)
10 (0.39)	5 (0.20)	40 (1.57)	5.5 (0.22)	9.0 x 7.0 dp (0.35 x 0.28 dp)	M5x0.8	8.4 (0.33)	-	-	25 (1)
14 (0.55)	7 (0.28)	34 (1.34)	5.5 (0.22)	9.0 x 7.0 dp (0.35 x 0.28 dp)	1/8*	8.7 (0.34)	49.3 (1.94)	16.5 (0.65)	32 (1-1/4)
14 (0.55)	7 (0.28)	40 (1.57)	5.5 (0.22)	9.0 x 7.0 dp (0.35 x 0.28 dp)	1/8*	9.2 (0.36)	57.0 (2.24)	17.8 (0.70)	40 (1-1/2)
17 (0.67)	8 (0.31)	50 (1.97)	6.6 (0.26)	11.0 x 8.0 dp (0.43 x 0.31 dp)	1/4*	10.5 (0.41)	70.6 (2.78)	22.2 (0.88)	50 (2)
17 (0.67)	8 (0.31)	60 (2.36)	9 (0.35)	13.7 x 10.5 dp (0.54 x 0.41 dp)	1/4*	11.5 (0.45)	83.6 (3.29)	22.2 (0.88)	63 (2-1/2)
22 (0.87)	10 (0.39)	77 (3.03)	11 (0.43)	16.8 x 13.5 dp (0.66 x 0.53 dp)	3/8*	14.0 (0.55)	104 (4.09)	27.0 (1.06)	80 (3-1/4)
27 (1.06)	12 (0.47)	94 (3.70)	11 (0.43)	16.8 x 13.5 dp (0.66 x 0.53 dp)	3/8*	18.0 (0.71)	121.9 (4.80)	27.0 (1.06)	100 (4)

Global Series™ Cylinders

– Magnetic Piston

Ø12 - Ø25 mm Bores

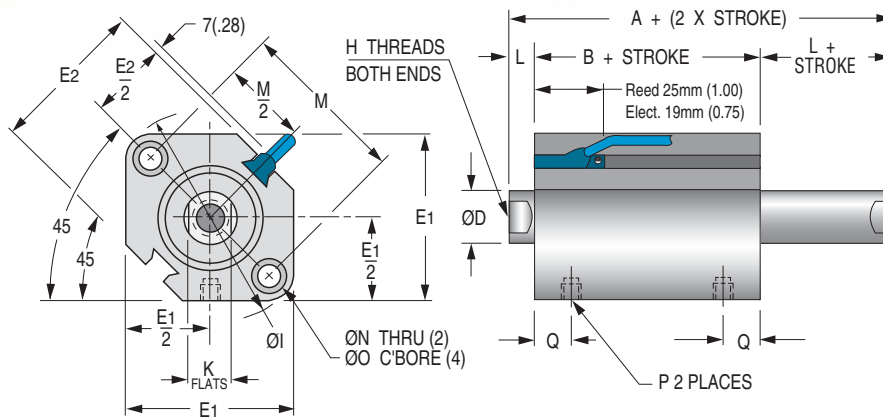
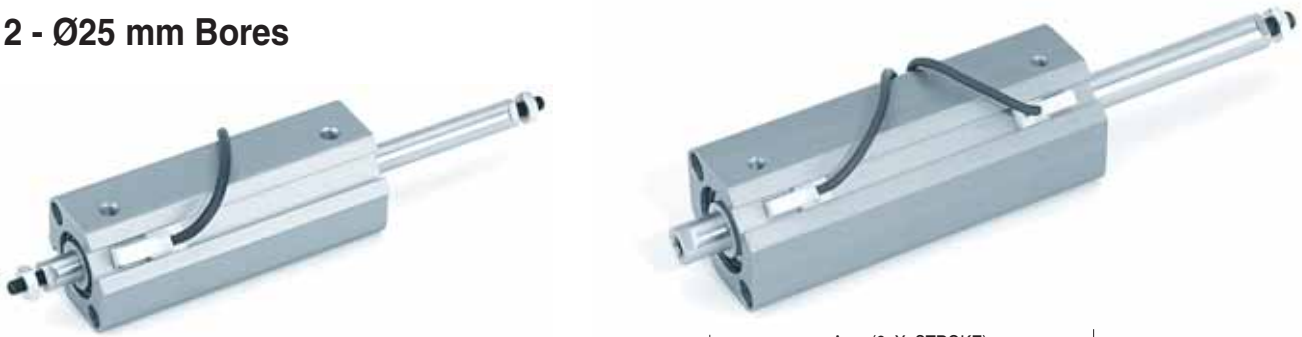

Dimensional Data

Note 1- See page 4 for complete stroke availability
 Note 2- Chart dimensions are shown as mm (inches)

Bore mm	Long Stroke				Extended Stroke			
	Stroke mm	A	B	Q	Stroke mm	A	B	Q
12	–	–	–	–	50, 75, 100	40.8 (1.61)	33.8 (1.33)	8.9 (.35)
16	–	–	–	–	50, 75, 100	43.2 (1.70)	36.2 (1.42)	10.2 (.40)
20	–	–	–	–	75, 100	50.6 (1.99)	41.6 (1.64)	12.1 (.48)
25	–	–	–	–	75, 100	57.5 (2.26)	47.5 (1.87)	12.7 (.50)
32	75, 100	61.8 (2.43)	47.8 (1.88)	12.7 (.50)	125, 150	61.8 (2.43)	47.8 (1.88)	12.7 (.50)
40	75, 100	69.5 (2.74)	55.5 (2.19)	12.7 (.50)	125, 150	69.5 (2.74)	55.5 (2.19)	12.7 (.50)
50	75, 100	75.3 (2.96)	59.3 (2.33)	13.2 (.52)	125, 150	75.3 (2.96)	59.3 (2.33)	13.2 (.52)
63	75, 100	80.6 (3.17)	64.6 (2.54)	18.5 (.73)	125, 150	80.6 (3.17)	64.6 (2.54)	18.5 (.73)
80	75, 100	89.5 (3.52)	69.5 (2.74)	14.0 (.55)	125, 150	89.5 (3.52)	69.5 (2.74)	14.0 (.55)
100	75, 100	100.7 (3.96)	76.7 (3.02)	18.0 (.71)	125, 150	100.7 (3.96)	76.7 (3.02)	18.0 (.71)

Model Code 'T'	
Bore	Hole Size
12	NA (NA)
16	1.5 (.06)
20	1.5 (.06)
25	3.1 (.13)
32	3.1 (.13)
40	3.1 (.13)
50	4.0 (.16)
63	4.0 (.16)
80	6.3 (.25)
100	6.3 (.25)

Bore mm (Nom. Inch)	Stroke Range	A	B	ØD	E1	E2	H (Threads) x dp minimum inch or metric	ØI
12 (1/2)	5~30 (0.20~1.18)	39.4 (1.55)	32.4 (1.28)	6 (0.236)	25 (0.98)	23 (0.90)	#8-32 x .21dp M3 x 0.5 – 5 dp	31.5 (1.24)
16 (5/8)	5~30 (0.20~1.18)	43.0 (1.69)	36.0 (1.42)	8 (0.315)	29 (1.14)	27.2 (1.07)	#8-32 x .21dp M4 x 0.7 – 5 dp	37.1 (1.46)
20 (3/4)	5~50 (0.20~2.0)	47.0 (1.85)	38.0 (1.50)	10 (0.394)	36 (1.42)	31.2 (1.23)	#10-32 x .28 dp M5 x 0.8 – 7 dp	47 (1.85)
25 (1)	5~50 (0.20~2.0)	49.0 (1.93)	39 (1.54)	12 (0.472)	40 (1.57)	36.9 (1.45)	1/4-28 x .39 dp M6 x 1.0 – 10 dp	51.3 (2.02)
32 (1-1/4)	5~50 (0.20~2.0)	54.5 (2.15)	40.5 (1.59)	16 (0.630)	44.5 (1.75)	–	5/16-24 x .50 dp M8 x 1.25 – 12 dp	58.9 (2.32)
40 (1-1/2)	5~50 (0.20~2.0)	64.0 (2.52)	50.0 (1.97)	16 (0.630)	52 (2.05)	–	3/8-24 x .50 dp M8 x 1.25 – 12 dp	69 (2.72)
50 (2)	10~50 (0.39~2.0)	66.5 (2.62)	50.5 (1.99)	20 (0.787)	63.7 (2.51)	–	1/2-20 x .50 dp M10 x 1.5 – 12 dp	84.9 (3.34)
63 (2-1/2)	10~50 (0.39~2.0)	68.0 (2.68)	52.0 (2.05)	20 (0.787)	76.7 (3.02)	–	1/2-20 x .50 dp M10 x 1.5 – 12 dp	101.8 (4.01)
80 (3-1/4)	10~50 (0.39~2.0)	81.0 (3.19)	61.0 (2.40)	25 (0.984)	97.8 (3.85)	–	5/8-18 x .88 dp M16 x 2.0 – 22 dp	129.8 (5.11)
100 (4)	10~50 (0.39~2.0)	94.5 (3.72)	70.5 (2.78)	30 (1.181)	115.3 (4.54)	–	3/4-16 x .88 dp M20 x 2.5 – 22 dp	153.9 (6.06)

Double Acting, Double Rod Models

Ø32 - Ø100 mm Bores

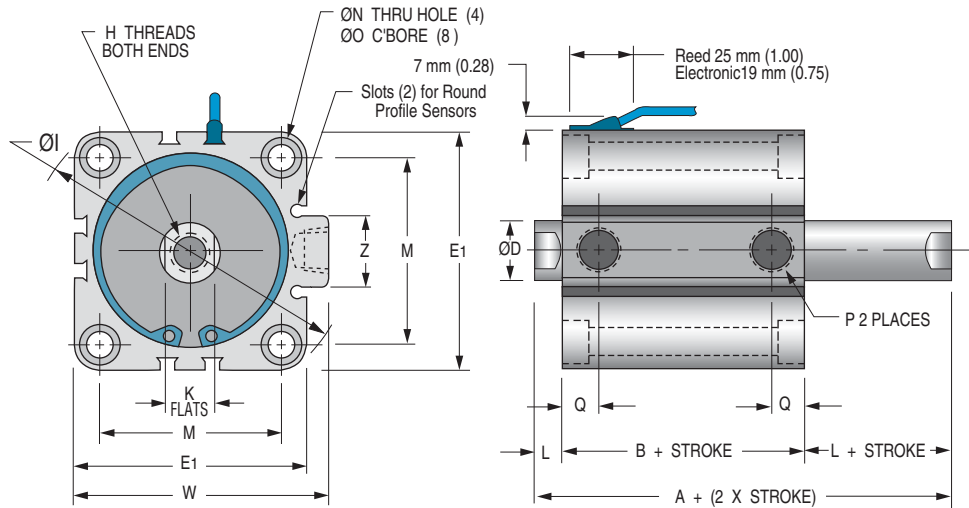

Sensors must be ordered separately. See page 37.

* Port Size Offerings

See dim. column "P" below

- N**- NPT ports, inch rod thread
 - G**- BSP parallel ports, metric rod thread
 - P**- BSPT taper ports, metric rod thread
- Note: M5 x 0.8 port will accept #10-32 male thread fittings.

Rod end male thread			
Bore mm	AF (HEX) inch or mm	HM (THREADS) inch or metric	LM inch or mm
12	.34 or 8	#8-32 x .31 lg or M5 x 0.8 - 9 lg	0.45 or 14.0
16	.34 or 10	#8-32 x .31 lg or M6 x 1.0 - 10 lg	0.45 or 15.5
20	.38 or 13	#10-32 x .31 lg or M8 x 1.25 - 12 lg	0.49 or 18.5
25	.43 or 17	1/4-28 x .37 lg or M10 x 1.25 - 15 lg	0.57 or 22.5
32	.50 or 22	5/16-24 x .50 lg or M14 x 1.5 - 20.5 lg	0.78 or 28.5
40	.56 or 22	3/8-24 x .63 lg or M14 x 1.5 - 20.5 lg	0.91 or 28.5
50	.75 or 27	1/2-20 x .77 lg or M18 x 1.5 - 26 lg	1.08 or 33.5
63	.75 or 27	1/2-20 x .77 lg or M18 x 1.5 - 26 lg	1.08 or 33.5
80	.93 or 32	5/8-18 x 1.00 lg or M22 x 1.5 - 32.5 lg	1.40 or 43.5
100	1.13 or 46	3/4-16 x 1.12 lg or M26 x 1.5 - 32.5 lg	1.59 or 43.5

Tapped hole mounting		
Bore mm	O (THREADS) inch or metric	R inch or mm
12	#8-32 or M4 x 0.7	0.43 or 11
16	#8-32 or M4 x 0.7	0.43 or 11
20	1/4-20 or M6 x 1.0	0.67 or 17
25	1/4-20 or M6 x 1.0	0.67 or 17
32	1/4-20 or M6 x 1.0	0.67 or 17
40	1/4-20 or M6 x 1.0	0.75 or 19
50	5/16-18 or M8 x 1.25	0.75 or 19
63	7/16-14 or M10 x 1.5	0.87 or 22
80	1/2-13 or M12 x 1.75	1.13 or 29
100	1/2-13 or M12 x 1.75	1.13 or 29

Note: Inch threads for 'N' port code. Metric threads for 'G' & 'P' port codes. Metric for foot or flange mount.

K	L	M	ØN	ØO	*P	Q	W	Z	Bore mm (Nom. Inch)
5 (0.20)	3.5 (0.14)	22 (0.87)	3.5 (0.14)	6.5 x 3.5 dp (0.26 x 0.14 dp)	M5x0.8	7.0 (0.28)	-	-	12 (1/2)
6 (0.24)	3.5 (0.14)	28 (1.10)	3.5 (0.14)	6.5 x 3.5 dp (0.26 x 0.14 dp)	M5x0.8	7.8 (0.31)	-	-	16 (5/8)
8 (0.31)	4.5 (0.18)	36 (1.42)	5.5 (0.22)	9.0 x 7.0 dp (0.35 x 0.28 dp)	M5x0.8	8.1 (0.32)	-	-	20 (3/4)
10 (0.39)	5 (0.20)	40 (1.57)	5.5 (0.22)	9.0 x 7.0 dp (0.35 x 0.28 dp)	M5x0.8	8.4 (0.33)	-	-	25 (1)
14 (0.55)	7 (0.28)	34 (1.34)	5.5 (0.22)	9.0 x 7.0 dp (0.35 x 0.28 dp)	1/8*	8.7 (0.34)	49.3 (1.94)	16.5 (0.65)	32 (1-1/4)
14 (0.55)	7 (0.28)	40 (1.57)	5.5 (0.22)	9.0 x 7.0 dp (0.35 x 0.28 dp)	1/8*	9.2 (0.36)	57.0 (2.24)	17.8 (0.70)	40 (1-1/2)
17 (0.67)	8 (0.31)	50 (1.97)	6.6 (0.26)	11.0 x 8.0 dp (0.43 x 0.31 dp)	1/4*	10.5 (0.41)	70.6 (2.78)	22.2 (0.88)	50 (2)
17 (0.67)	8 (0.31)	60 (2.36)	9 (0.35)	13.7 x 10.5 dp (0.54 x 0.41 dp)	1/4*	11.5 (0.45)	83.6 (3.29)	22.2 (0.88)	63 (2-1/2)
22 (0.87)	10 (0.39)	77 (3.03)	11 (0.43)	16.8 x 13.5 dp (0.66 x 0.53 dp)	3/8*	14.0 (0.55)	104 (4.09)	27.0 (1.06)	80 (3-1/4)
27 (1.06)	12 (0.47)	94 (3.70)	11 (0.43)	16.8 x 13.5 dp (0.66 x 0.53 dp)	3/8*	18.0 (0.71)	121.9 (4.80)	27.0 (1.06)	100 (4)

Global Series™ Cylinders

– Magnetic Piston

Ø12 - Ø25 mm Bores

Sensors must be ordered separately. See page 37.

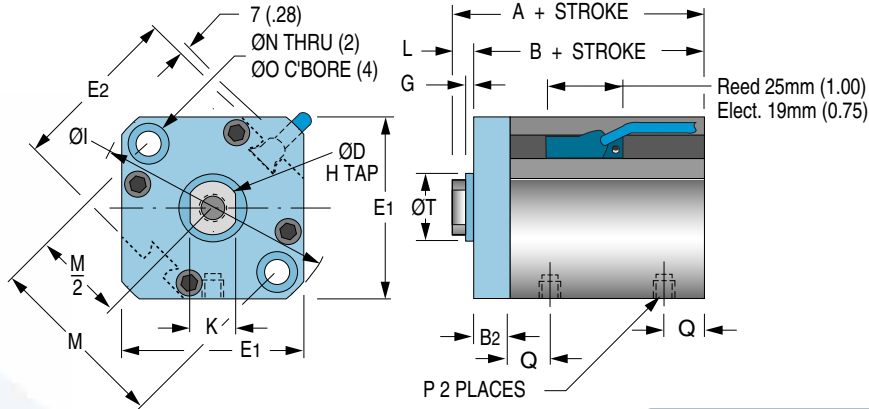
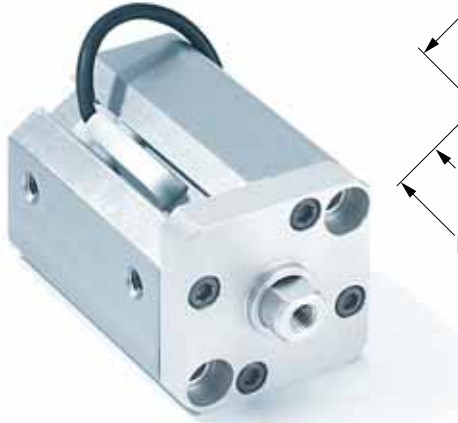

Rod flats (Dim. K) nominally in-line with ports

Bore mm	B2
12	5 (.20)
16	5 (.20)
20	8 (.32)
25	8 (.32)

Warning
THIS CYLINDER HAS A NON-ROTATING ROD. TO PREVENT INTERNAL DAMAGE HOLD ROD BY FLATS ONLY WHEN FULLY RETRACTED WHILE INSTALLING OR REMOVING ATTACHMENTS. DO NOT SCRATCH OR DENT SHAFT.

Dimensional Data

Note 1- See page 4 for complete stroke availability
Note 2- Chart dimensions are shown as mm (inches)

Bore size	12	16	20	25	32	40	50	63	80	100
Nonrotating rod accuracy	±2°	±1°	±1°	±1°	±0.8°	±0.8°	±0.8°	±0.8°	±0.8°	±0.8°

Bore mm	Long Stroke				Extended Stroke			
	Stroke mm	A	B	Q	Stroke mm	A	B	Q
12	–	–	–	–	50, 75, 100	42.3 (1.67)	38.8 (1.53)	8.9 (.35)
16	–	–	–	–	50, 75, 100	44.7 (1.76)	41.2 (1.62)	10.2 (.40)
20	–	–	–	–	75, 100	54.1 (2.13)	49.6 (1.95)	12.1 (.48)
25	–	–	–	–	75, 100	60.5 (2.38)	55.5 (2.19)	12.7 (.50)
32	75, 100	49.0 (1.93)	42.0 (1.65)	8.7 (.34)	125, 150	63.8 (2.51)	56.8 (2.24)	12.7 (.50)
40	75, 100	46.5 (1.83)	39.5 (1.56)	9.2 (.36)	125, 150	62.5 (2.46)	55.5 (2.19)	12.7 (.50)
50	75, 100	48.5 (1.91)	40.5 (1.59)	10.5 (.41)	125, 150	67.3 (2.65)	59.3 (2.33)	13.2 (.52)
63	75, 100	54.0 (2.13)	46.0 (1.81)	11.5 (.45)	125, 150	72.6 (2.86)	64.6 (2.54)	18.5 (.73)
80	75, 100	63.5 (2.50)	53.5 (2.11)	14.0 (.55)	125, 150	79.5 (3.13)	69.5 (2.74)	14.0 (.55)
100	75, 100	75.0 (2.95)	63.0 (2.48)	18.0 (.71)	125, 150	88.7 (3.49)	76.7 (3.02)	18.0 (.71)

*** Port Size Offerings**
See dim. column "P" below
N– NPT ports, inch rod thread
G– BSP parallel ports, metric rod thread
P– BSPT taper ports, metric rod thread
Note: M5 x 0.8 port will accept #10-32 male thread fittings.

Bore mm (Nom. Inch)	Stroke Range	A	B	ØD	E1	E2	H (Threads) x dp minimum inch or metric	ØI
12 (1/2)	5~30 (0.20~1.18)	36.5 (1.44)	33.0 (1.30)	6 (0.236)	25 (0.98)	23 (0.90)	#8-32 x .21dp M3 x 0.5 – 5 dp	31.5 (1.24)
16 (5/8)	5~30 (0.20~1.18)	39.0 (1.54)	35.5 (1.40)	8 (0.315)	29 (1.14)	27.2 (1.07)	#8-32 x .21dp M4 x 0.7 – 5 dp	37.1 (1.46)
20 (3/4)	5~50 (0.20~2.0)	44.0 (1.73)	39.5 (1.56)	10 (0.394)	36 (1.42)	31.2 (1.23)	#10-32 x .28 dp M5 x 0.8 – 7 dp	47 (1.85)
25 (1)	5~50 (0.20~2.0)	45.5 (1.79)	40.5 (1.59)	12 (0.472)	40 (1.57)	36.9 (1.45)	1/4-28 x .39 dp M6 x 1.0 – 10 dp	51.3 (2.02)
32 (1-1/4)	5~50 (0.20~2.0)	49.0 (1.93)	42.0 (1.65)	16 (0.630)	44.5 (1.75)	–	5/16-24 x .50 dp M8 x 1.25 – 12 dp	58.9 (2.32)
40 (1-1/2)	5~50 (0.20~2.0)	46.5 (1.83)	39.5 (1.56)	16 (0.630)	52 (2.05)	–	3/8-24 x .50 dp M8 x 1.25 – 12 dp	69 (2.72)
50 (2)	10~50 (0.39~2.0)	48.5 (1.91)	40.5 (1.59)	20 (0.787)	63.7 (2.51)	–	1/2-20 x .50 dp M10 x 1.5 – 12 dp	84.9 (3.34)
63 (2-1/2)	10~50 (0.39~2.0)	54.0 (2.13)	46.0 (1.81)	20 (0.787)	76.7 (3.02)	–	1/2-20 x .50 dp M10 x 1.5 – 12 dp	101.8 (4.01)
80 (3-1/4)	10~50 (0.39~2.0)	63.5 (2.50)	53.5 (2.11)	25 (0.984)	97.8 (3.85)	–	5/8-18 x .88 dp M16 x 2.0 – 22 dp	129.8 (5.11)
100 (4)	10~50 (0.39~2.0)	75.0 (2.95)	63.0 (2.48)	30 (1.181)	115.3 (4.54)	–	3/4-16 x .88 dp M20 x 2.5 – 22 dp	153.9 (6.06)

Double Acting, Non-Rotating Piston Rod Models

Ø32 mm Bore

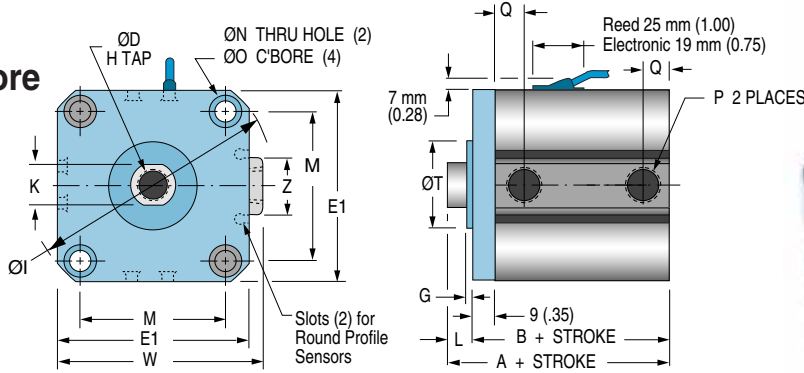

Ø40- Ø100 mm Bores

See page 37 for round profile sensors featuring surge suppression, polarity protection and dual output.

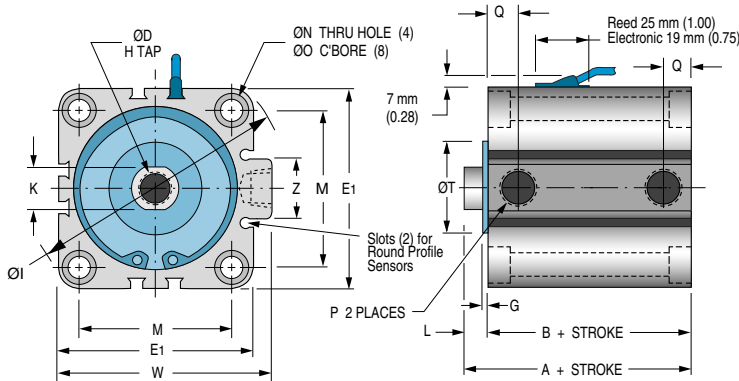

Rod flats (Dim. K) nominally in-line with ports

Bore mm (Nom. Inch)	ØT	G
12 (1/2)	15 +0/- 0.043 (0.591 +0/-0.002)	1.5 (0.059)
16 (5/8)	20 +0/- 0.052 (0.787 +0/-0.002)	1.5 (0.059)
20 (3/4)	13 +0/- 0.043 (0.512 +0/-0.002)	2.0 (0.079)
25 (1)	15 +0/- 0.043 (0.591 +0/-0.002)	2.0 (0.079)
32 (1-1/4)	21 +0/- 0.062 (0.827 +0/-0.002)	2.0 (0.079)
40 (1-1/2)	28 +0/- 0.062 (1.102 +0/-0.002)	2.0 (0.079)
50 (2)	35 +0/- 0.062 (1.378 +0/-0.002)	2.0 (0.079)
63 (2-1/2)	35 +0/- 0.062 (1.378 +0/-0.002)	2.0 (0.079)
80 (3-1/4)	43 +0/- 0.062 (1.693 +0/-0.002)	2.0 (0.079)
100 (4)	59 +0/- 0.074 (2.323 +0/-0.003)	2.0 (0.079)

Rod end male thread

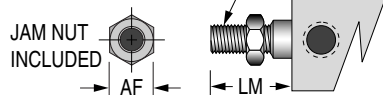

Bore mm	AF (HEX) inch or mm	HM (THREADS) inch or metric	LM inch or mm
12	.34 or 8	#8-32 x .31 lg or M5 x 0.8 - 9 lg	0.45 or 14.0
16	.34 or 10	#8-32 x .31 lg or M6 x 1.0 - 10 lg	0.45 or 15.5
20	.38 or 13	#10-32 x .31 lg or M8 x 1.25 - 12 lg	0.49 or 18.5
25	.43 or 17	1/4-28 x .37 lg or M10 x 1.25 - 15 lg	0.57 or 22.5
32	.50 or 22	5/16-24 x .50 lg or M14 x 1.5 - 20.5 lg	0.78 or 28.5
40	.56 or 22	3/8-24 x .63 lg or M14 x 1.5 - 20.5 lg	0.91 or 28.5
50	.75 or 27	1/2-20 x .77 lg or M18 x 1.5 - 26 lg	1.08 or 33.5
63	.75 or 27	1/2-20 x .77 lg or M18 x 1.5 - 26 lg	1.08 or 33.5
80	.93 or 32	5/8-18 x 1.00 lg or M22 x 1.5 - 32.5 lg	1.40 or 43.5
100	1.13 or 46	3/4-16 x 1.12 lg or M26 x 1.5 - 32.5 lg	1.59 or 43.5

Tapped hole mounting

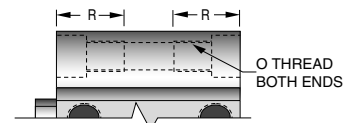

Bore mm	O (THREADS) inch or metric	Places Front	RF inch or mm	Places Rear	RR inch or mm
12	#8-32 or M4 x 0.7	2	0.63 or 16	2	0.43 or 11
16	#8-32 or M4 x 0.7	2	0.63 or 16	2	0.43 or 11
20	1/4-20 or M6 x 1.0	2	0.98 or 25	2	0.67 or 17
25	1/4-20 or M6 x 1.0	2	0.98 or 25	2	0.67 or 17
32	1/4-20 or M6 x 1.0	2	1.02 or 26	4	0.67 or 17
40	1/4-20 or M6 x 1.0	4	0.75 or 19	4	0.75 or 19
50	5/16-18 or M8 x 1.25	4	0.75 or 19	4	0.75 or 19
63	7/16-14 or M10 x 1.5	4	0.87 or 22	4	0.87 or 22
80	1/2-13 or M12 x 1.75	4	1.13 or 29	4	1.13 or 29
100	1/2-13 or M12 x 1.75	4	1.13 or 29	4	1.13 or 29

K	L	M	ØN	ØO	*P	Q	W	Z	Bore mm (Nom. Inch)
5.2 (0.20)	3.5 (0.14)	22 (0.87)	3.5 (0.14)	6.5 x 3.5 dp (0.26 x 0.14 dp)	M5x0.8	7.0 (0.28)	-	-	12 (1/2)
6 (0.24)	3.5 (0.14)	28 (1.10)	3.5 (0.14)	6.5 x 3.5 dp (0.26 x 0.14 dp)	M5x0.8	7.8 (0.31)	-	-	16 (5/8)
8 (0.31)	4.5 (0.18)	36 (1.42)	5.5 (0.22)	9.0 x 7.0 dp (0.35 x 0.28 dp)	M5x0.8	8.1 (0.32)	-	-	20 (3/4)
10 (0.39)	5 (0.20)	40 (1.57)	5.5 (0.22)	9.0 x 7.0 dp (0.35 x 0.28 dp)	M5x0.8	8.4 (0.33)	-	-	25 (1)
14 (0.55)	7 (0.28)	34 (1.34)	5.5 (0.22)	9.0 x 7.0 dp (0.35 x 0.28 dp)	1/8*	8.7 (0.34)	49.3 (1.94)	16.5 (0.65)	32 (1-1/4)
14 (0.55)	7 (0.28)	40 (1.57)	5.5 (0.22)	9.0 x 7.0 dp (0.35 x 0.28 dp)	1/8*	9.2 (0.36)	57.0 (2.24)	17.8 (0.70)	40 (1-1/2)
18 (0.71)	8 (0.31)	50 (1.97)	6.6 (0.26)	11.0 x 8.0 dp (0.43 x 0.31 dp)	1/4*	10.5 (0.41)	70.6 (2.78)	22.2 (0.88)	50 (2)
18 (0.71)	8 (0.31)	60 (2.36)	9 (0.35)	13.7 x 10.5 dp (0.54 x 0.41 dp)	1/4*	11.5 (0.45)	83.6 (3.29)	22.2 (0.88)	63 (2-1/2)
22 (0.87)	10 (0.39)	77 (3.03)	11 (0.43)	16.8 x 13.5 dp (0.66 x 0.53 dp)	3/8*	14.0 (0.55)	104 (4.09)	27.0 (1.06)	80 (3-1/4)
27 (1.06)	12 (0.47)	94 (3.70)	11 (0.43)	16.8 x 13.5 dp (0.66 x 0.53 dp)	3/8*	18.0 (0.71)	121.9 (4.80)	27.0 (1.06)	100 (4)

Global Series™ Cylinders

– Magnetic Piston

Warning

THIS CYLINDER HAS A NON-ROTATING ROD. TO PREVENT INTERNAL DAMAGE HOLD ROD BY FLATS ONLY WHEN FULLY RETRACTED WHILE INSTALLING OR REMOVING ATTACHMENTS. DO NOT SCRATCH OR DENT SHAFT.

Sensors must be ordered separately. See page 37.



Ø12 - Ø25 mm Bores

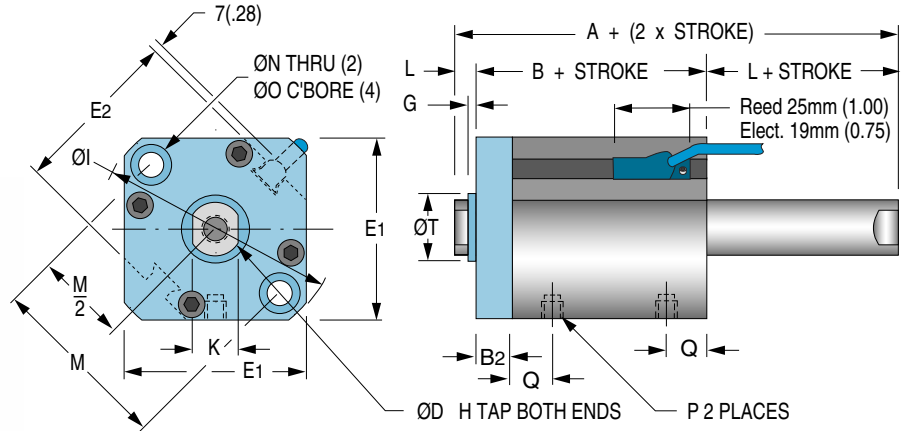

Rod flats (Dim. K) nominally in-line with ports

Bore mm	B2
12	5 (.20)
16	5 (.20)
20	8 (.32)
25	8 (.32)

Dimensional Data

Bore size	12	16	20	25	32	40	50	63	80	100
Nonrotating rod accuracy	±2°	±1°	±1°	±1°	±0.8°	±0.8°	±0.8°	±0.8°	±0.8°	±0.8°

Bore mm	Long Stroke				Extended Stroke				Model Code 'M'	
	Stroke mm	A	B	Q	Stroke mm	A	B	Q	Bore	Hole Size
12	–	–	–	–	50, 75, 100	45.8 (1.80)	38.8 (1.53)	8.9 (.35)	12	NA (NA)
16	–	–	–	–	50, 75, 100	48.2 (1.90)	41.2 (1.62)	10.2 (.40)	16	1.5 (.06)
20	–	–	–	–	75, 100	58.6 (2.31)	49.6 (1.95)	12.1 (.48)	20	1.5 (.06)
25	–	–	–	–	75, 100	65.5 (2.58)	55.5 (2.19)	12.7 (.50)	25	3.1 (.13)
32	75, 100	70.8 (2.79)	56.8 (2.24)	12.7 (.50)	125, 150	70.8 (2.79)	56.8 (2.24)	12.7 (.50)	32	3.1 (.13)
40	75, 100	69.5 (2.74)	55.5 (2.19)	12.7 (.50)	125, 150	69.5 (2.74)	55.5 (2.19)	12.7 (.50)	40	3.1 (.13)
50	75, 100	75.3 (2.96)	59.3 (2.33)	13.2 (.52)	125, 150	75.3 (2.96)	59.3 (2.33)	13.2 (.52)	50	4.0 (.16)
63	75, 100	80.6 (3.17)	64.6 (2.54)	18.5 (.73)	125, 150	80.6 (3.17)	64.6 (2.54)	18.5 (.73)	63	4.0 (.16)
80	75, 100	89.5 (3.52)	69.5 (2.74)	14.0 (.55)	125, 150	89.5 (3.52)	69.5 (2.74)	14.0 (.55)	80	6.3 (.25)
100	75, 100	100.7 (3.96)	76.7 (3.02)	18.0 (.71)	125, 150	100.7 (3.96)	76.7 (3.02)	18.0 (.71)	100	6.3 (.25)

Bore mm (Nom. Inch)	Stroke Range	A	B	ØD	E1	E2	H (Threads) x dp minimum inch or metric	ØI
12 (1/2)	5~30 (0.20~1.18)	44.4 (1.75)	37.4 (1.47)	6 (0.236)	25 (0.98)	23 (0.90)	#8-32 x .21dp M3 x 0.5 – 5 dp	31.5 (1.24)
16 (5/8)	5~30 (0.20~1.18)	48.0 (1.89)	41.0 (1.61)	8 (0.315)	29 (1.14)	27.2 (1.07)	#8-32 x .21dp M4 x 0.7 – 5 dp	37.1 (1.46)
20 (3/4)	5~50 (0.20~2.0)	55.0 (2.17)	46.0 (1.81)	10 (0.394)	36 (1.42)	31.2 (1.23)	#10-32 x .28 dp M5 x 0.8 – 7 dp	47 (1.85)
25 (1)	5~50 (0.20~2.0)	57.0 (2.24)	47.0 (1.85)	12 (0.472)	40 (1.57)	36.9 (1.45)	1/4-28 x .39 dp M6 x 1.0 – 10 dp	51.3 (2.02)
32 (1-1/4)	5~50 (0.20~2.0)	63.5 (2.50)	49.5 (1.95)	16 (0.630)	44.5 (1.75)	–	5/16-24 x .50 dp M8 x 1.25 – 12 dp	58.9 (2.32)
40 (1-1/2)	5~50 (0.20~2.0)	64.0 (2.52)	50.0 (1.97)	16 (0.630)	52 (2.05)	–	3/8-24 x .50 dp M8 x 1.25 – 12 dp	69 (2.72)
50 (2)	10~50 (0.39~2.0)	66.5 (2.62)	50.5 (1.99)	20 (0.787)	63.7 (2.51)	–	1/2-20 x .50 dp M10 x 1.5 – 12 dp	84.9 (3.34)
63 (2-1/2)	10~50 (0.39~2.0)	68.0 (2.68)	52.0 (2.05)	20 (0.787)	76.7 (3.02)	–	1/2-20 x .50 dp M10 x 1.5 – 12 dp	101.8 (4.01)
80 (3-1/4)	10~50 (0.39~2.0)	81.0 (3.19)	61.0 (2.40)	25 (0.984)	97.8 (3.85)	–	5/8-18 x .88 dp M16 x 2.0 – 22 dp	129.8 (5.11)
100 (4)	10~50 (0.39~2.0)	94.5 (3.72)	70.5 (2.78)	30 (1.181)	115.3 (4.54)	–	3/4-16 x .88 dp M20 x 2.5 – 22 dp	153.9 (6.06)

Double Acting, Double Rod, Nonrotating Piston Rod Models

Ø32 mm Bore

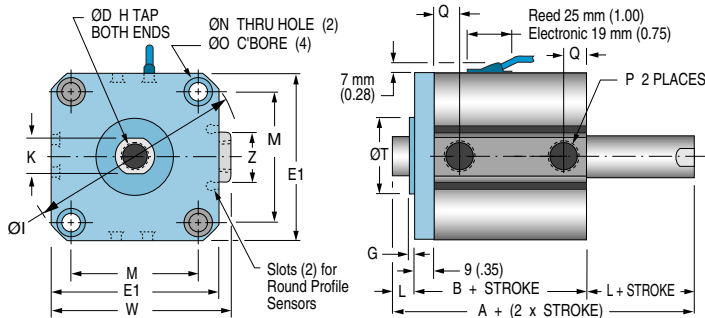

Rod flats (Dim. K) nominally in-line with ports

* Port Size Offerings

See dim. column "P" below

- N**– NPT ports, inch rod thread
 - G**– BSP parallel ports, metric rod thread
 - P**– BSPT taper ports, metric rod thread
- Note: M5 x 0.8 port will accept #10-32 male thread fittings.

Bore mm (Nom. Inch)	ØT	G
12 (1/2)	15 +0/- 0.043 (0.591 +0/-0.002)	1.5 (0.059)
16 (5/8)	20 +0/- 0.052 (0.787 +0/-0.002)	1.5 (0.059)
20 (3/4)	13 +0/- 0.043 (0.512 +0/-0.002)	2.0 (0.079)
25 (1)	15 +0/- 0.043 (0.591 +0/-0.002)	2.0 (0.079)
32 (1-1/4)	21 +0/- 0.062 (0.827 +0/-0.002)	2.0 (0.079)
40 (1-1/2)	28 +0/- 0.062 (1.102 +0/-0.002)	2.0 (0.079)
50 (2)	35 +0/- 0.062 (1.378 +0/-0.002)	2.0 (0.079)
63 (2-1/2)	35 +0/- 0.062 (1.378 +0/-0.002)	2.0 (0.079)
80 (3-1/4)	43 +0/- 0.062 (1.693 +0/-0.002)	2.0 (0.079)
100 (4)	59 +0/- 0.074 (2.323 +0/-0.003)	2.0 (0.079)

Ø40- Ø100 mm Bores

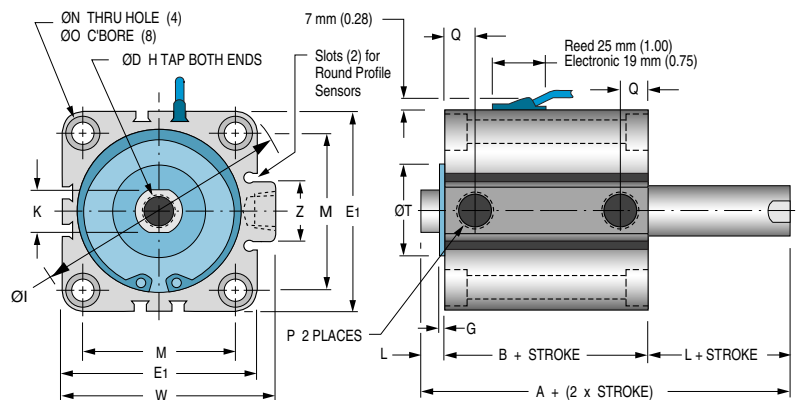

Rod end male thread

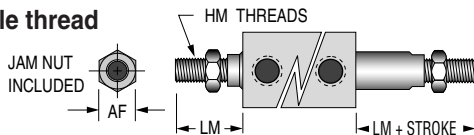

Bore mm	AF (HEX) inch or mm	HM (THREADS) inch or metric	LM inch or mm
12	.34 or 8	#8-32 x .31 lg or M5 x 0.8 - 9 lg	0.45 or 14.0
16	.34 or 10	#8-32 x .31 lg or M6 x 1.0 - 10 lg	0.45 or 15.5
20	.38 or 13	#10-32 x .31 lg or M8 x 1.25 - 12 lg	0.49 or 18.5
25	.43 or 17	1/4-28 x .37 lg or M10 x 1.25 - 15 lg	0.57 or 22.5
32	.50 or 22	5/16-24 x .50 lg or M14 x 1.5 - 20.5 lg	0.78 or 28.5
40	.56 or 22	3/8-24 x .63 lg or M14 x 1.5 - 20.5 lg	0.91 or 28.5
50	.75 or 27	1/2-20 x .77 lg or M18 x 1.5 - 26 lg	1.08 or 33.5
63	.75 or 27	1/2-20 x .77 lg or M18 x 1.5 - 26 lg	1.08 or 33.5
80	.93 or 32	5/8-18 x 1.00 lg or M22 x 1.5 - 32.5 lg	1.40 or 43.5
100	1.13 or 46	3/4-16 x 1.12 lg or M26 x 1.5 - 32.5 lg	1.59 or 43.5

Tapped hole mounting

Note: Inch threads for 'N' port code. Metric threads for 'G' & 'P' port codes. Metric for foot, flange, or clevis mount.

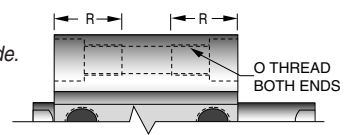

Bore mm	O (THREADS) inch or metric	Places Front	RF		RR	
			inch or mm	Places Rear	inch or mm	
12	#8-32 or M4 x 0.7	2	0.63 or 16	2	0.43 or 11	
16	#8-32 or M4 x 0.7	2	0.63 or 16	2	0.43 or 11	
20	1/4-20 or M6 x 1.0	2	0.98 or 25	2	0.67 or 17	
25	1/4-20 or M6 x 1.0	2	0.98 or 25	2	0.67 or 17	
32	1/4-20 or M6 x 1.0	2	1.02 or 26	4	0.67 or 17	
40	1/4-20 or M6 x 1.0	4	0.75 or 19	4	0.75 or 19	
50	5/16-18 or M8 x 1.25	4	0.75 or 19	4	0.75 or 19	
63	7/16-14 or M10 x 1.5	4	0.87 or 22	4	0.87 or 22	
80	1/2-13 or M12 x 1.75	4	1.13 or 29	4	1.13 or 29	
100	1/2-13 or M12 x 1.75	4	1.13 or 29	4	1.13 or 29	

K	L	M	ØN	ØO	*P	Q	W	Z	Bore mm (Nom. Inch)
5.2 (0.20)	3.5 (0.14)	22 (0.87)	3.5 (0.14)	6.5 x 3.5 dp (0.26 x 0.14 dp)	M5x0.8	7.0 (0.28)	-	-	12 (1/2)
6 (0.24)	3.5 (0.14)	28 (1.10)	3.5 (0.14)	6.5 x 3.5 dp (0.26 x 0.14 dp)	M5x0.8	7.8 (0.31)	-	-	16 (5/8)
8 (0.31)	4.5 (0.18)	36 (1.42)	5.5 (0.22)	9.0 x 7.0 dp (0.35 x 0.28 dp)	M5x0.8	8.1 (0.32)	-	-	20 (3/4)
10 (0.39)	5 (0.20)	40 (1.57)	5.5 (0.22)	9.0 x 7.0 dp (0.35 x 0.28 dp)	M5x0.8	8.4 (0.33)	-	-	25 (1)
14 (0.55)	7 (0.28)	34 (1.34)	5.5 (0.22)	9.0 x 7.0 dp (0.35 x 0.28 dp)	1/8*	8.7 (0.34)	49.3 (1.94)	16.5 (0.65)	32 (1-1/4)
14 (0.55)	7 (0.28)	40 (1.57)	5.5 (0.22)	9.0 x 7.0 dp (0.35 x 0.28 dp)	1/8*	9.2 (0.36)	57.0 (2.24)	17.8 (0.70)	40 (1-1/2)
18 (0.71)	8 (0.31)	50 (1.97)	6.6 (0.26)	11.0 x 8.0 dp (0.43 x 0.31 dp)	1/4*	10.5 (0.41)	70.6 (2.78)	22.2 (0.88)	50 (2)
18 (0.71)	8 (0.31)	60 (2.36)	9 (0.35)	13.7 x 10.5 dp (0.54 x 0.41 dp)	1/4*	11.5 (0.45)	83.6 (3.29)	22.2 (0.88)	63 (2-1/2)
22 (0.87)	10 (0.39)	77 (3.03)	11 (0.43)	16.8 x 13.5 dp (0.66 x 0.53 dp)	3/8*	14.0 (0.55)	104 (4.09)	27.0 (1.06)	80 (3-1/4)
27 (1.06)	12 (0.47)	94 (3.70)	11 (0.43)	16.8 x 13.5 dp (0.66 x 0.53 dp)	3/8*	18.0 (0.71)	121.9 (4.80)	27.0 (1.06)	100 (4)

Global Series™ Cylinders – Magnetic Piston

Precision Stroke Adjustment Emphasizing Operator Safety

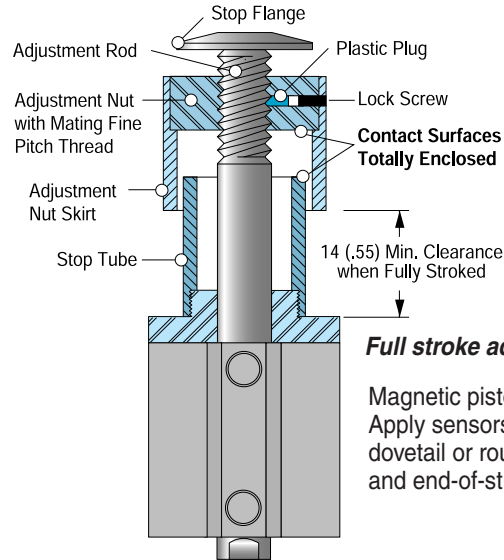

Full stroke adjustment on all strokes.

Magnetic piston is a standard feature. Apply sensors (ordered separately) to dovetail or round slots for mid-stroke and end-of-stroke sensing.

Adjustable Extend Stroke Cylinders – Fabco-Air's popular Dial-A-Stroke® adjustment assembly is now available on Global Series™ Cylinders to provide a rugged, precision adjustment of the cylinder extend stroke.

Cylinders are offered in double acting models in bore sizes of 32mm through 100mm with full stroke adjustment.

Magnetic pistons are included for use with any of the electronic or reed sensors. Sensors must be ordered separately. See page 37.

Operator Safety –

The stop tube, adjustment nut with skirt, and minimum clearances combine to eliminate pinch points.

Construction –

The stop tube is black anodized aluminum – the adjustment nut is blackened steel with a black anodized aluminum skirt – the stop flange is red anodized aluminum: all for corrosion resistance and appearance.

The adjustment nut, steel for long life, includes a lock screw with a plastic plug so the adjustment nut can be locked in place without damaging the threads. Precision adjustment is achieved with fine pitch threads on the adjustment rod.

The stop flange is mounted on the end of the adjustment rod so the nut will not come off.

Adjustment –

Adjustment settings are simplified by the convenient scale markings. Bores 32 and 40 have a 1/2-20 thread giving .050" (1.3mm) adjustment per nut revolution. Bores 50 and larger have a 3/4-16 thread giving .063" (1.6mm) adjustment per revolution.

How to Order

(See page 9 - model codes A & AK; see page 29 - mounting codes.)

Example 1: To order a 63mm bore, 75mm stroke unit with Dial-a-Stroke®, NPT ports, and rod end tap mount, specify

Model No. **GND-AA063-075D**

Example 2: Also available with non-rotating rod; use body length 'B' dimension from page 26, tapped hole mounting information from page 27 and insert the non-rotating rod Code 'K' in model number. To order 63mm bore, 75mm stroke, nonrotating rod, with Dial-a-Stroke®, NPT ports, and ISO flange specify

Model No. **GND-AKG063-075D**

Note – When ordering units with flange or foot mounts, the rod stickout (Dim. "L") increases per dimension on pages 31 or 32.

Note - Chart dimensions are shown as mm (inches)

Dimensional Data

BORE mm (Nom. Inch)	STROKE mm		ØD	E1	H (THREADS) inch or metric	ØI	K	L	M
	15, 25, 50 B	75, 100, 125, 150 B							
32 (1-1/4)	40.5 (1.59)	47.8 (1.88)	16 (0.630)	44.5 (1.75)	5/16-24 x .52 dp M8 x 1.25 – 13 dp	58.9 (2.32)	14 (0.55)	7 (0.28)	34 (1.34)
40 (1-1/2)	50.0 (1.97)	55.5 (2.19)	16 (0.630)	52 (2.05)	3/8-24 x .72 dp M8 x 1.25 – 13 dp	69.0 (2.72)	14 (0.55)	7 (0.28)	40 (1.57)
50 (2)	50.5 (1.99)	59.3 (2.33)	20 (0.787)	63.7 (2.51)	1/2-20 x .69 dp M10 x 1.5 – 12 dp	84.9 (3.34)	17 (0.67)	8 (0.31)	50 (1.97)
63 (2-1/2)	52.0 (2.05)	64.6 (2.54)	20 (0.787)	76.7 (3.02)	1/2-20 x .69 dp M10 x 1.5 – 12 dp	101.8 (4.01)	17 (0.67)	8 (0.31)	60 (2.36)
80 (3-1/4)	61.0 (2.40)	69.5 (2.74)	25 (0.984)	97.8 (3.85)	5/8-18 x .96 dp M16 x 2.0 – 21dp	129.8 (5.11)	22 (0.87)	10 (0.39)	77 (3.03)
100 (4)	70.5 (2.78)	76.7 (3.02)	30 (1.181)	115.3 (4.54)	3/4-16 x 1.06 dp M20 x 2.5 – 30 dp	153.9 (6.06)	27 (1.06)	12 (0.47)	94 (3.70)

Dial-A-Stroke® Adjustable Extend Stroke Models

Ø32 - Ø100 mm Bores

Standard mounting – Code "A" Tapped Holes
 4 places useable at rod end only.
 Also includes 2 thru holes ØN w/c'bore ØO
 Optional mounting – See "How to Order" note page 28.
 Code "E" Front Flange
 Code "G" ISO Front Flange
 Code "L" Foot Mount

Note! ! Use caution when mounting to avoid creating pinch points with other parts of your machinery

Also available with Nonrotating rod. See page 28 example 2.

Sensors must be ordered separately. See page 37.

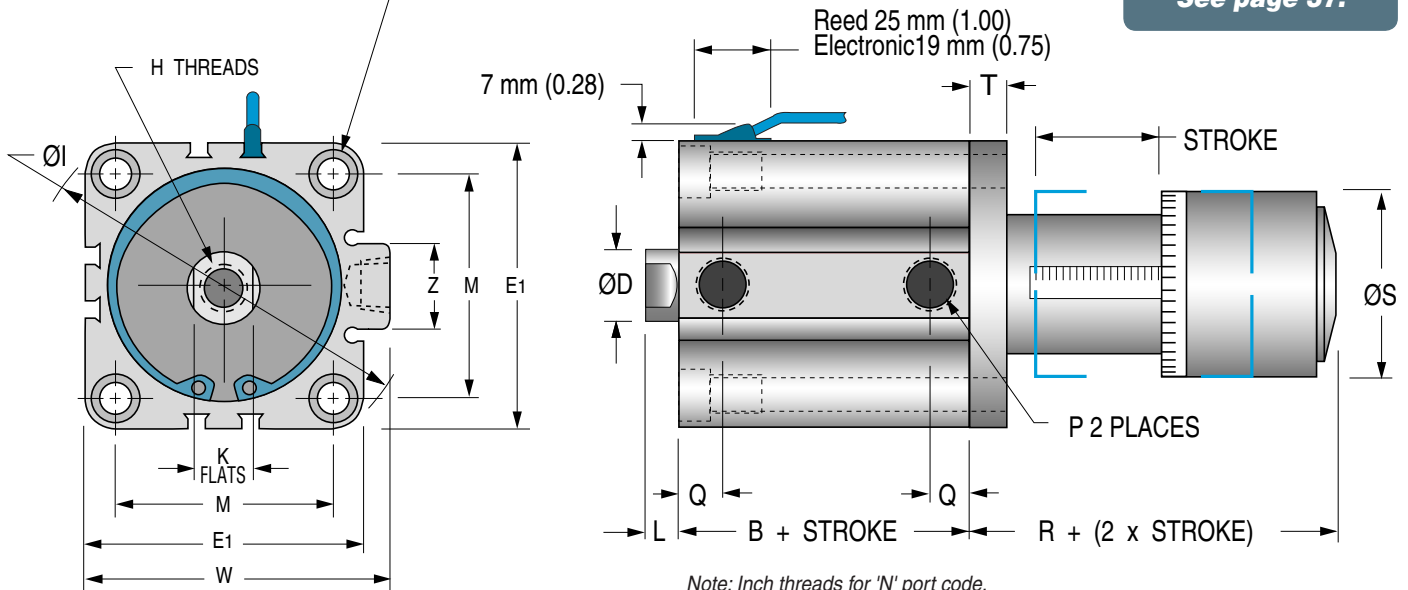

Note: Inch threads for 'N' port code.
 Metric threads for 'G' & 'P' port codes.
 Metric for foot, flange, or clevis mount.

Rod end male thread

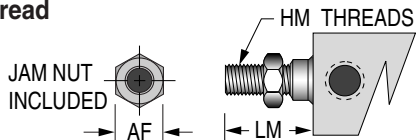

Tapped hole mounting

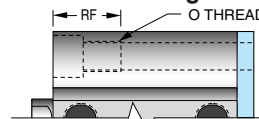

BORE mm	AF (HEX) inch or mm	HM (THREADS) inch or metric	LM inch or mm
32	.50 or 22	5/16-24 x .50 lg or M14 x 1.5 - 20.5 lg	0.78 or 28.5
40	.56 or 22	3/8-24 x .63 lg or M14 x 1.5 - 20.5 lg	0.91 or 28.5
50	.75 or 27	1/2-20 x .77 lg or M18 x 1.5 - 26 lg	1.08 or 33.5
63	.75 or 27	1/2-20 x .77 lg or M18 x 1.5 - 26 lg	1.08 or 33.5
80	.93 or 32	5/8-18 x 1.00 lg or M22 x 1.5 - 32.5 lg	1.40 or 43.5
100	1.13 or 46	3/4-16 x 1.12 lg or M26 x 1.5 - 32.5 lg	1.59 or 43.5

Bore mm	O (THREADS) inch or metric	RF inch or mm
32	1/4-20 or M6 x 1.0	0.67 or 17
40	1/4-20 or M6 x 1.0	0.75 or 19
50	5/16-18 or M8 x 1.25	0.75 or 19
63	7/16-14 or M10 x 1.5	0.87 or 22
80	1/2-13 or M12 x 1.75	1.13 or 29
100	1/2-13 or M12 x 1.75	1.13 or 29

* Port Size Offerings

See dim. column "P" below

- N**– NPT ports, inch rod thread
- G**– BSP parallel ports, metric rod thread
- P**– BSPT taper ports, metric rod thread

ØN	ØO	*P	STROKE mm		R	ØS	T	W	Z	Bore mm (Nom. Inch)
			15, 25, 50 Q	75, 100, 125, 150 Q						
5.5 (0.22)	9.0 x 7.0 dp (0.35 x 0.28 dp)	1/8*	8.7 (0.34)	12.7 (0.50)	41.1 (1.62)	38 (1.5)	7.6 (.30)	49.3 (1.94)	16.5 (0.65)	32 (1-1/4)
5.5 (0.22)	9.0 x 7.0 dp (0.35 x 0.28 dp)	1/8*	9.2 (0.36)	12.7 (0.50)	41.1 (1.62)	38 (1.5)	7.6 (.30)	57.0 (2.24)	17.8 (0.70)	40 (1-1/2)
6.6 (0.26)	11.0 x 8.0 dp (0.43 x 0.31 dp)	1/4*	10.5 (0.41)	13.2 (0.52)	53.6 (2.11)	50.8 (2.0)	12.0 (.47)	70.6 (2.78)	22.2 (0.88)	50 (2)
9 (0.35)	13.7 x 10.5 dp (0.54 x 0.41 dp)	1/4*	11.5 (0.45)	18.5 (0.73)	52.6 (2.07)	50.8 (2.0)	11.0 (.43)	83.6 (3.29)	22.2 (0.88)	63 (2-1/2)
11 (0.43)	16.8 x 13.5 dp (0.66 x 0.53 dp)	3/8*	14.0 (0.55)	14.0 (0.55)	56.6 (2.23)	50.8 (2.0)	15.0 (.59)	104 (4.09)	27.0 (1.06)	80 (3-1/4)
11 (0.43)	16.8 x 13.5 dp (0.66 x 0.53 dp)	3/8*	18.0 (0.71)	18.0 (0.71)	65.1 (2.56)	50.8 (2.0)	15.0 (.59)	121.9(4.80)	27.0 (1.06)	100 (4)

Global Series™ Cylinders – Rear Clevis Mount



Ø12 - Ø25 mm Bores

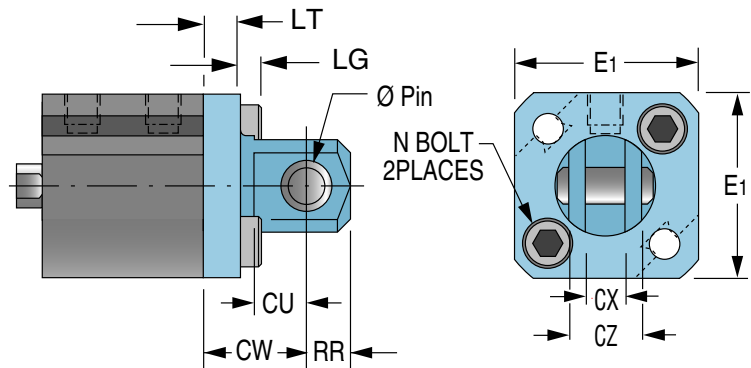

Ø32 - Ø100 mm Bores

Note: All clevis mounts attach to cylinder body with metric size socket cap screws

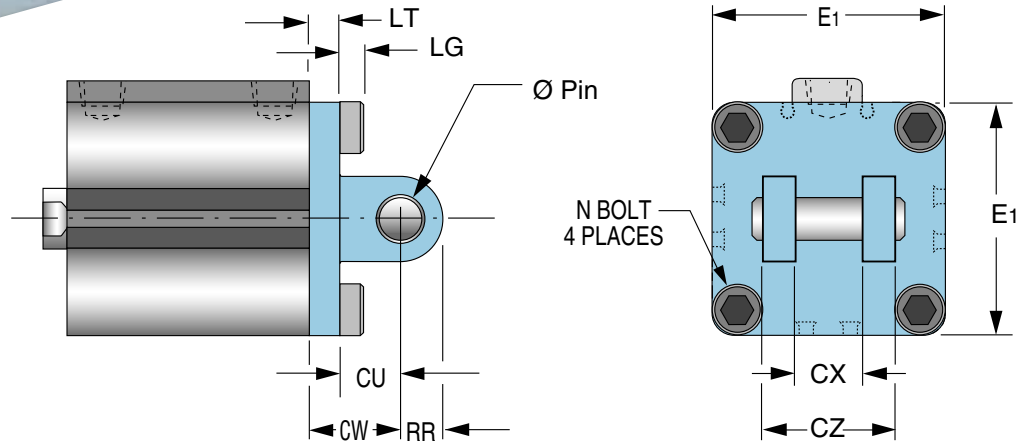

Note:
Pin diameter will be inch size for cylinders with port code 'N' and mm size for cylinders with port code 'G' or 'P'.

Bore mm	N BOLT
12	M4x0.7
16	M4x0.7
20	M6x1.0
25	M6x1.0
32	M6x1.0
40	M6x1.0
50	M8x1.25
63	M10x1.5
80	M12x1.75
100	M12x1.75

Rear Clevis Mount Dimensions

Bore mm (Nom. Inch)	Ø Pin Nominal mm or inch	CW	CU	CX	CZ	LT	LG	RR	E1
12 (1/2)	5 or .187	14 (0.55)	7.0 (0.28)	5.3 (0.21)	10 (0.39)	5 (0.20)	2.8 (0.11)	6.0 (0.24)	25 (0.98)
16 (5/8)	5 or .187	15 (0.59)	10 (0.39)	6.8 (0.27)	12 (0.47)	5 (0.20)	2.8 (0.11)	6.0 (0.24)	29 (1.14)
20 (3/4)	8 or .312	18 (0.71)	12 (0.47)	8.3 (0.33)	16 (0.63)	5 (0.20)	4.0 (0.16)	9.0 (0.35)	36 (1.42)
25 (1)	10 or .375	20 (0.79)	14 (0.55)	10.3 (0.41)	20 (0.79)	5 (0.20)	4.0 (0.16)	10 (0.39)	40 (1.57)
32 (1-1/4)	10 or .375	20 (0.79)	14 (0.55)	18.3 (0.72)	36 (1.42)	6 (0.24)	4.0 (0.16)	10 (0.39)	44.5 (1.75)
40 (1-1/2)	10 or .375	22 (0.87)	14 (0.55)	18.3 (0.72)	36 (1.42)	8 (0.31)	4.0 (0.16)	10 (0.39)	52 (2.05)
50 (2)	14 or .500	28 (1.10)	20 (0.79)	22.3 (0.88)	44 (1.73)	8 (0.31)	5.0 (0.20)	14 (0.55)	63.7 (2.51)
63 (2-1/2)	14 or .500	30 (1.18)	20 (0.79)	22.3 (0.88)	44 (1.73)	10 (0.39)	6.0 (0.24)	14 (0.55)	76.7 (3.02)
80 (3-1/4)	18 or .750	38 (1.50)	27 (1.07)	28.3 (1.11)	56 (2.20)	11 (0.43)	7.0 (0.28)	18 (0.71)	97.8 (3.85)
100 (4)	22 or .875	45 (1.77)	31 (1.22)	32.3 (1.27)	64 (2.52)	14 (0.55)	7.0 (0.28)	22 (0.87)	115.3 (4.54)



Ø12 - Ø25 mm Bores

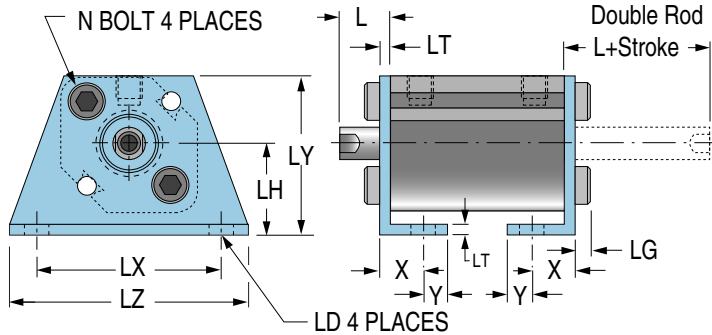

Ø32 - Ø100 mm Bores

Note: All feet attach to cylinder body with metric size socket cap screws

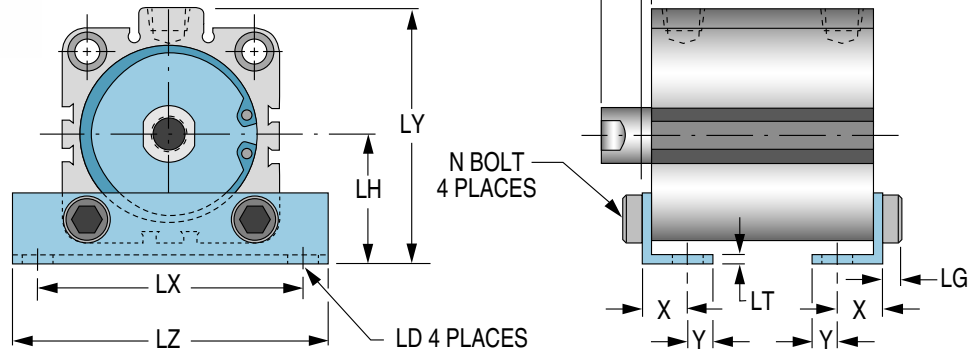

Bore mm	N BOLT
12	M4x0.7
16	M4x0.7
20	M6x1.0
25	M6x1.0
32	M6x1.0
40	M6x1.0
50	M8x1.25
63	M10x1.5
80	M12x1.75
100	M12x1.75

Foot Mount Dimensions

Bore mm (Nom. Inch)	LD	LH	LX	LY	LZ	L	LT	X	Y	LG
12 (1/2)	4.5 (0.18)	17 (0.67)	34 (1.34)	29.5 (1.16)	44 (1.73)	13.5 (0.53)	2 (0.08)	8 (0.31)	4.5 (0.18)	2.8 (0.11)
16 (5/8)	4.5 (0.18)	19 (0.75)	38 (1.50)	33.5 (1.32)	48 (1.89)	13.5 (0.53)	2 (0.08)	8 (0.31)	5.0 (0.20)	2.8 (0.11)
20 (3/4)	6.6 (0.26)	24 (0.94)	48 (1.89)	42.0 (1.65)	62 (2.44)	14.5 (0.57)	3.2 (0.13)	9.2 (0.36)	5.8 (0.23)	4.0 (0.16)
25 (1)	6.6 (0.26)	26 (1.02)	52 (2.05)	46.0 (1.81)	66 (2.60)	15 (0.59)	3.2 (0.13)	10.7 (0.42)	5.8 (0.23)	4.0 (0.16)
32 (1-1/4)	6.6 (0.26)	30 (1.18)	57 (2.24)	57.0 (2.24)	71 (2.80)	17 (0.67)	3.2 (0.13)	11.2 (0.44)	5.8 (0.23)	4.0 (0.16)
40 (1-1/2)	6.6 (0.26)	33 (1.30)	64 (2.52)	64.0 (2.52)	78 (3.07)	17 (0.67)	3.2 (0.13)	11.2 (0.44)	7.0 (0.28)	4.0 (0.16)
50 (2)	9.0 (0.35)	39 (1.54)	79 (3.11)	78.0 (3.07)	95 (3.74)	18 (0.71)	3.2 (0.13)	14.7 (0.58)	8.0 (0.31)	5.0 (0.20)
63 (2-1/2)	11 (0.43)	46 (1.81)	95 (3.74)	91.5 (3.60)	113 (4.45)	18 (0.71)	3.2 (0.13)	16.2 (0.64)	9.0 (0.35)	6.0 (0.24)
80 (3-1/4)	13 (0.51)	59 (2.32)	118 (4.65)	114 (4.49)	140 (5.51)	20 (0.79)	4.5 (0.18)	19.5 (0.77)	11.0 (0.43)	7.0 (0.28)
100 (4)	13 (0.51)	71 (2.80)	137 (5.39)	136 (5.35)	162 (6.38)	22 (0.87)	6.0 (0.24)	23 (0.91)	12.5 (0.49)	7.0 (0.28)

Global Series™ Cylinders – Flange Mounts

Front Flange Ø12 - Ø25 mm Bores

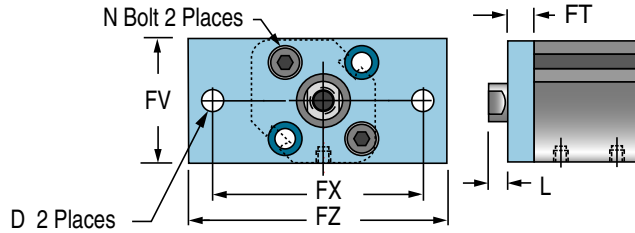

Rear Flange Ø12 - Ø25 mm Bores

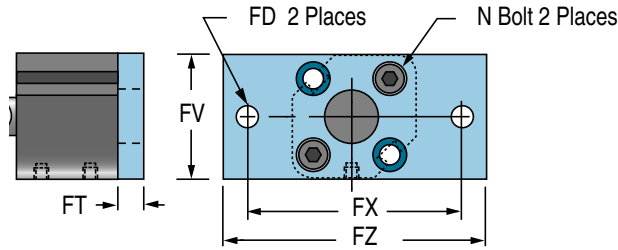

Note: All flanges attach to cylinder body with metric size flat head socket screws

Front Flange Ø32 - Ø100 mm Bores

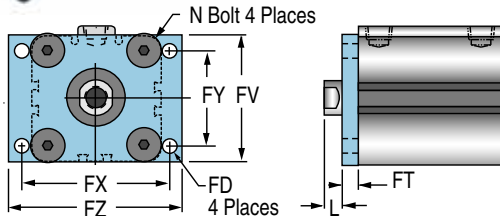

Rear Flange Ø32 - Ø100 mm Bores

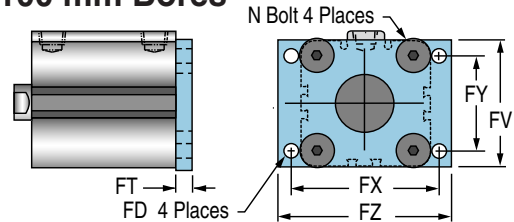

Flange Mount Dimensions

Bore mm	ISO Rectangular Flange Dimensions				
	FD	FY	FX	FV	FZ
12	5.5 (0.22)	–	40 (1.57)	25 (0.98)	50 (1.97)
16	5.5 (0.22)	–	40 (1.57)	30 (1.18)	50 (1.97)
20	6.6 (0.26)	–	50 (1.97)	39 (1.54)	62 (2.44)
25	6.6 (0.26)	–	50 (1.97)	42 (1.65)	62 (2.44)
32	7 (0.28)	32 (1.26)	64 (2.52)	48 (1.89)	76 (2.99)
40	9 (0.35)	36 (1.42)	72 (2.83)	54 (2.13)	88 (3.47)
50	9 (0.35)	45 (1.77)	90 (3.54)	67 (2.64)	106 (4.17)
63	9 (0.35)	50 (1.97)	100 (3.94)	80 (3.15)	116 (4.57)
80	12 (0.47)	63 (2.48)	126 (4.96)	99 (3.90)	150 (5.91)
100	14 (0.55)	75 (2.95)	150 (5.91)	117 (4.61)	178 (7.01)

Bore mm (Nom. Inch)	Common Dimensions			Interchange (Non-ISO) Flange Dimensions				
	FT	L	N Bolt	FD	FY	FX	FV	FZ
12 (1/2)	5.5 (0.22)	8.0 (0.31)	M4 x 0.7	4.5 (0.18)	–	45 (1.77)	25 (0.98)	55 (2.17)
16 (5/8)	5.5 (0.22)	8.0 (0.31)	M4 x 0.7	4.5 (0.18)	–	45 (1.77)	30 (1.18)	55 (2.17)
20 (3/4)	8 (0.31)	6.5 (0.26)	M6 x 1.0	6.6 (0.26)	–	48 (1.89)	39 (1.54)	60 (2.36)
25 (1)	8 (0.31)	7.0 (0.28)	M6 x 1.0	6.6 (0.26)	–	52 (2.05)	42 (1.65)	64 (2.52)
32 (1-1/4)	8 (0.31)	9.0 (0.35)	M6 x 1.0	5.5 (0.22)	34 (1.34)	56 (2.20)	48 (1.89)	65 (2.56)
40 (1-1/2)	8 (0.31)	9.0 (0.35)	M6 x 1.0	5.5 (0.22)	40 (1.57)	62 (2.44)	54 (2.13)	72 (2.83)
50 (2)	9 (0.35)	9.0 (0.35)	M8 x 1.25	6.6 (0.26)	50 (1.97)	76 (2.99)	67 (2.64)	89 (3.50)
63 (2-1/2)	9 (0.35)	9.0 (0.35)	M10 x 1.5	9 (0.35)	60 (2.36)	92 (3.62)	80 (3.15)	108 (4.25)
80 (3-1/4)	11 (0.43)	9.0 (0.35)	M12 x 1.75	11 (0.43)	77 (3.03)	116 (4.57)	99 (3.90)	134 (5.28)
100 (4)	11 (0.43)	11 (0.43)	M12 x 1.75	11 (0.43)	94 (3.70)	136 (5.35)	117 (4.61)	154 (6.06)

- Front & Rear Boss Mounts

Rear Boss Ø12 - Ø25 mm Bores

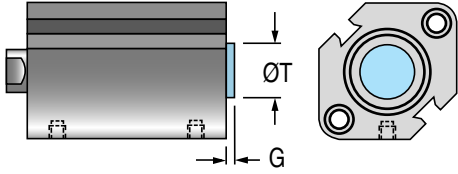

Front Boss Ø12 - Ø25 mm Bores

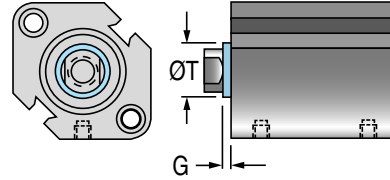

Rear Boss Ø32 - Ø100 mm Bores

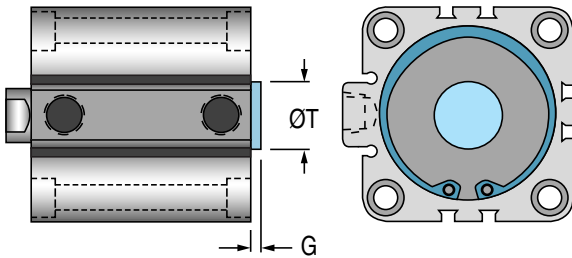

Front Boss Ø32 - Ø100 mm Bores

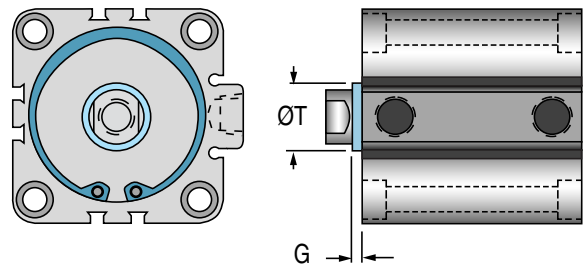

Boss Mount Dimensions

Bore mm (Nom. Inch)	ØT	G
12 (1/2)	15 +0/- 0.043 (0.591 +0/-0.002)	1.5 (0.059)
16 (5/8)	20 +0/- 0.052 (0.787 +0/-0.002)	1.5 (0.059)
20 (3/4)	13 +0/- 0.043 (0.512 +0/-0.002)	2.0 (0.079)
25 (1)	15 +0/- 0.043 (0.591 +0/-0.002)	2.0 (0.079)
32 (1-1/4)	21 +0/- 0.062 (0.827 +0/-0.002)	2.0 (0.079)
40 (1-1/2)	28 +0/- 0.062 (1.102 +0/-0.002)	2.0 (0.079)
50 (2)	35 +0/- 0.062 (1.378 +0/-0.002)	2.0 (0.079)
63 (2-1/2)	35 +0/- 0.062 (1.378 +0/-0.002)	2.0 (0.079)
80 (3-1/4)	43 +0/- 0.062 (1.693 +0/-0.002)	2.0 (0.079)
100 (4)	59 +0/- 0.074 (2.323 +0/-0.003)	2.0 (0.079)

Global Series™ Cylinders

Back-to-Back Cylinders – Option XC10

Note 1: Available double acting only
Note 2: Magnetic piston body style "D" includes magnet in both cylinder sections

Back-to-back cylinders are for use where three or four rod positions are required. Two cylinders are assembled back-to-back with bolts threaded into tapped end mounting holes.

Different strokes on each cylinder enable having four positive stop positions when the units are mounted at the rod ends.

Back-to-back cylinders provide independent piston rods on each end of the unit.

To order specify the desired strokes with a slash between the 3-digit stroke codes, then follow model number with option suffix -XC10

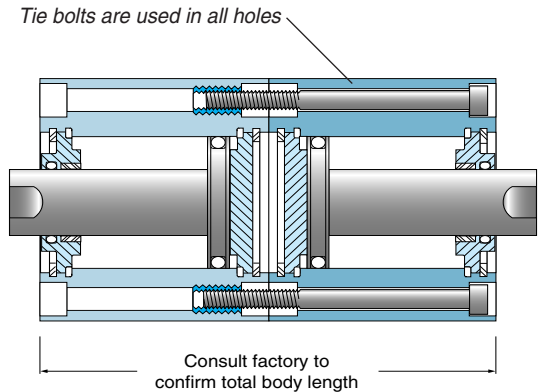
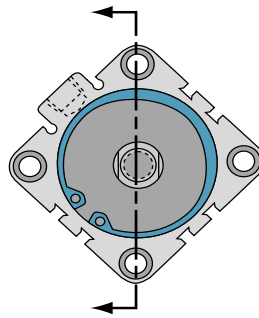

1. Ordering Example – Global Series, NPT ports, magnetic piston, 40mm bore, dual strokes of 30 and 50mm, bumpers both ends and male rod ends.

The Model Number is: GND – SB040 – 030 – B – M / – 050D – B – M – XC10

2. A non-rotating rod can be fitted to one section. The position of "K" model code determines the stroke of the non-rotating rod cylinder section.

Example: GNN – SKB040 – 030/050D – XC10

"S" Indicates 30 stroke single rod
"K" indicates 50 stroke non-rotating rod

Tandem Cylinders – Option XC11 & XC12

Note: Available double acting only

Tandem cylinders are generally used when three distinct rod positions are required. Two cylinders are assembled tip-to-tail with bolts threaded into the rear tapped mounting holes of the forward cylinder.

Using cylinders with two different strokes (the shorter located on the rear cylinder), enables a single rod to be extended to a positive mid-position or to full extension.

To order specify the desired strokes with a slash between the 3-digit stroke codes, then follow model number with option suffix -XC11 or -XC12

Note: More than three positions can be obtained by assembling multiple cylinders together. Please consult the factory for these special requirements.

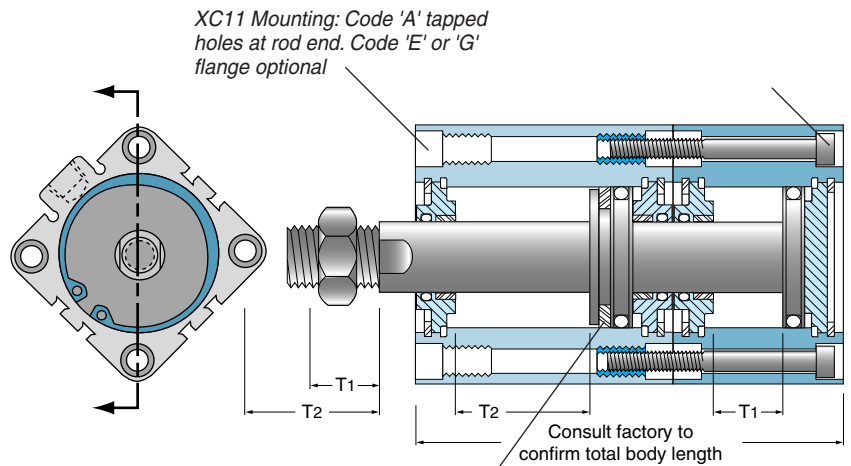

When a single magnetic piston is ordered, it is applied in the forward cylinder

Ordering Example – Global Series, BSPT ports, with single magnetic piston, 63mm bore, dual strokes of 75 and 100mm, and male rod thread.

The Model Number is: GPD – SA063 – 075/100D – M – XC11

When magnets and bumpers are required in both forward and rear cylinders, and tapped holes are required at cap end, order as

GPDD – SA063 – 075 – B/100D – B – M – XC12

– Cylinder Options and Universal Seal Kits

4 Position Application

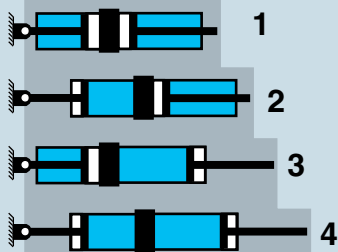

- Pressure applied to piston
- Open to atmosphere

Adjustable Retract Stroke – Option RS Available on Bores 20mm and Larger

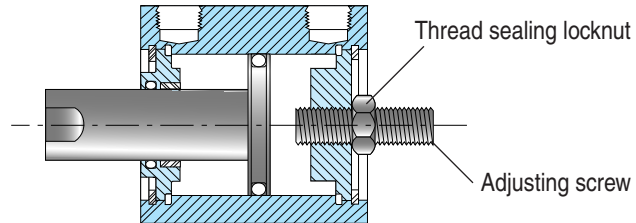

An adjusting screw with a thread sealing locknut mounted in a thick rear cover provides a simple, yet rugged adjustment of the cylinder stroke in the retract direction. The fine thread of the adjusting screw provides precision adjustment. Bores 20, 25 and 32mm have a 5/16-24 thread giving .042" (1.1mm) adjustment per revolution. Bores 40 thru 100mm have a 1/2-20 thread giving .050" (1.3mm) adjustment.

The adjustable retract stroke option is available on 20mm bores and larger for any stroke. Standard adjustment is up to and including 25mm.

For over 25mm adjustment specify adjustment length after the option designation RS.

Example:
for 50mm adjustment the option designation becomes RS-50

3 Position Application

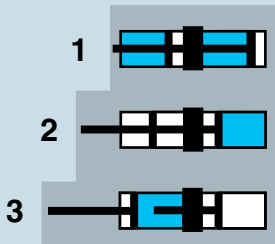

- Pressure applied to piston
- Open to atmosphere

Viton Seals – Option V

For elevated temperatures from -26C° to 204C° (-15F° to +400° F) or for compatibility with hostile media. Consult engineering for compatibility information.

Universal Seal Kits – For single and double rod cylinders and adjustable stroke models. Nonrotating rod seals are available separately. Seals for options are available on request.

Bore	Seal Kit		Non-Rotating Rod Seal
	Buna N	Viton	
12	G12 - SK	G12 - SKV	
16	G16 - SK	G16 - SKV	
20	G20 - SK	G20 - SKV	
25	G25 - SK	G25 - SKV	
32	G32 - SK	G32 - SKV	
40	G40 - SK	G40 - SKV	
50	G50 - SK	G50 - SKV	
63	G63 - SK	G63 - SKV	
80	G80 - SK	G80 - SKV	
100	G100 - SK	G100 - SKV	

Global Series™ Cylinders – Accessories

Rod Eye – To order a Rod Eye use the **Prefix RE–** followed by the thread size.

Example: For a 25mm bore cylinder the inch rod threads are 1/4-28.

The Rod Eye Part Number is **RE–1/4-28**

For #8-32 size, follow with –12 or –16 for bore. **Example: RE-8-32-16**

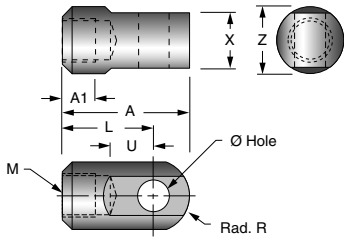

Bore mm (Nom. Inch)	L	U	X	Z	A1	A	R
12 (1/2)	16 (0.63)	7.0 (0.27)	4.7 (0.18)	9.7 (0.38)	6.0 (0.24)	21.5 (0.85)	6.3 (0.25)
16 (5/8)	25 (0.98)	14.0 (0.55)	6.2 (0.24)	11.2 (0.44)	6.0 (0.24)	32.0 (1.26)	12.0 (0.47)
20 (3/4)	25 (0.98)	11.5 (0.45)	7.7 (0.30)	16 (0.63)	6.0 (0.24)	34.0 (1.34)	10.3 (0.41)
25 (1)	30 (1.18)	14.0 (0.55)	9.7 (0.38)	19 (0.75)	8.0 (0.31)	41.0 (1.61)	12.8 (0.50)
32 (1-1/4)	30 (1.18)	14.0 (0.55)	17.6 (0.69)	22 (0.87)	14.0 (0.55)	42.0 (1.65)	12.0 (0.47)
40 (1-1/2)	30 (1.18)	14.0 (0.55)	17.6 (0.69)	22 (0.87)	14.0 (0.55)	42.0 (1.65)	12.0 (0.47)
50 (2)	40 (1.57)	20.0 (0.79)	21.6 (0.85)	27 (1.06)	18.0 (0.71)	56.0 (2.20)	16.0 (0.63)
63 (2-1/2)	40 (1.57)	20.0 (0.79)	21.6 (0.85)	27 (1.06)	18.0 (0.71)	56.0 (2.20)	16.0 (0.63)
80 (3-1/4)	50 (1.97)	27.0 (1.06)	27.6 (1.08)	38 (1.50)	21.0 (0.83)	71.0 (2.80)	21.0 (0.83)
100 (4)	55 (2.17)	31.0 (1.22)	31.6 (1.24)	44.5 (1.75)	21.0 (0.83)	79.0 (3.11)	24.0 (0.95)

Rod Clevis –

To order a Rod Clevis use the **Prefix RC–** followed by the thread size.

Example: For a 63mm bore cylinder the metric threads are M18 x 1.5. The Rod Clevis Part Number is **RC–M18x1.5**

For #8-32 size, follow with –12 or –16 for bore.

Example: RC-8-32-12

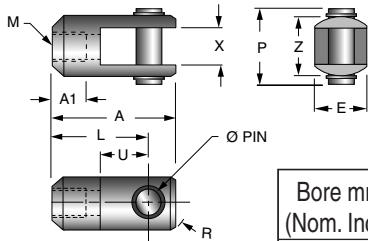

Bore	Ø Hole, Ø Pin Nominal	M Threads inch or metric
12	.187 or 5	#8-32 or M5 x 0.8
16	.187 or 5	#8-32 or M6 x 1.0
20	.312 or 8	#10-32 or M8 x 1.25
25	.375 or 10	1/4-28 or M10 x 1.25
32	.375 or 10	5/16-24 or M14 x 1.5
40	.375 or 10	3/8-24 or M14 x 1.5
50	.500 or 14	1/2-20 or M18 x 1.5
63	.500 or 14	1/2-20 or M18 x 1.5
80	.750 or 18	5/8-18 or M22 x 1.5
100	.875 or 22	3/4-16 or M26 x 1.5

Bore mm (Nom. Inch)	L	U	X	Z	P	E	A1	A	R
12 (1/2)	16 (0.63)	7.0 (0.27)	5.3 (0.21)	10 (0.39)	14 (0.55)	10 (0.39)	6.0 (0.24)	21.5 (0.85)	6.3 (0.25)
16 (5/8)	21 (0.83)	10.0 (0.39)	6.6 (0.26)	12 (0.47)	16 (0.63)	12 (0.47)	6.0 (0.24)	28.0 (1.10)	12.0 (0.47)
20 (3/4)	25 (0.98)	11.5 (0.45)	8.3 (0.33)	16 (0.63)	21 (0.83)	16 (0.63)	6.0 (0.24)	34.0 (1.34)	10.3 (0.41)
25 (1)	30 (1.18)	14.0 (0.55)	10.3 (0.41)	20 (0.78)	25 (0.98)	20 (0.78)	8.0 (0.31)	41.0 (1.61)	12.8 (0.50)
32 (1-1/4)	30 (1.18)	14.0 (0.55)	18.4 (0.72)	36.6 (1.44)	41 (1.61)	22 (0.87)	16.0 (0.63)	42.0 (1.65)	12.0 (0.47)
40 (1-1/2)	30 (1.18)	14.0 (0.55)	18.4 (0.72)	36.6 (1.44)	41 (1.61)	22 (0.87)	16.0 (0.63)	42.0 (1.65)	12.0 (0.47)
50 (2)	40 (1.57)	20.0 (0.79)	22.4 (0.88)	44.5 (1.75)	50 (1.97)	28 (1.10)	20.0 (0.79)	56.0 (2.20)	16.0 (0.63)
63 (2-1/2)	40 (1.57)	20.0 (0.79)	22.4 (0.88)	44.5 (1.75)	50 (1.97)	28 (1.10)	20.0 (0.79)	56.0 (2.20)	16.0 (0.63)
80 (3-1/4)	50 (1.97)	27.0 (1.06)	28.4 (1.12)	55.6 (2.19)	62.5 (2.46)	38 (1.50)	23.0 (0.91)	71.0 (2.80)	21.0 (0.83)
100 (4)	55 (2.17)	31.0 (1.22)	32.4 (1.28)	63.5 (2.50)	70.6 (2.78)	44 (1.73)	24.0 (0.95)	79.0 (3.11)	24.0 (0.95)

Note:
Pin diameter will be inch size for items with inch thread and mm size for items with metric thread.

8 mm Female Cordsets for Quick Disconnect Sensors

Cordset Description	Part No.
1 Meter, 3 Pin	CFC-1M
2 Meters, 3- Pin	CFC-2M
5 Meters, 3- Pin	CFC-5M

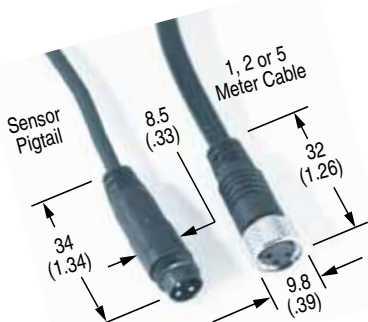

Male Connector on Sensor

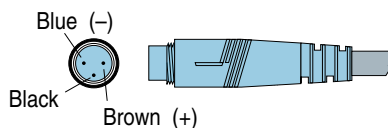

Female Connector on Cordset

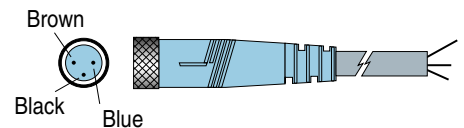

NEW – Low Profile Sensors for Magnetic Piston Cylinders

3/8" & 1/4" Dovetail Sensors

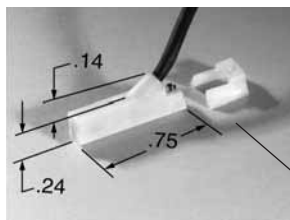

- Encased in a plastic housing, dovetail style sensors are corrosion resistant.
- 60° wire outlet allows close mounting.
- Sensors are mounted in dovetail slots in the wall of the cylinder and are actuated by a magnetic piston. Magnetic pistons are specified with Body Code "D" in the Global Series™ Cylinder model number.
- Two types of sensors are offered: Reed Switches and Electronic Sensors. **Sensors must be ordered separately from the tables below.**
- Each sensor is furnished complete with a set screw for secure installation.
- Mounting clamp included with 949-200-xxx models for 3/8" dovetail.

Installation for 3/8" Dovetail Sensors



- 1 Insert the mounting clamp into one of the dovetail slots and slide it to the approximate location desired. Position the sensor with its set screw facing the mounting clamp.
- 2 Set screw should be flush with the top surface of sensor. Push the sensor into its mounting clamp. Slide this assembly to the point of desired actuation.
- 3 Tighten the set screw to lock sensor in place..

Ordering Guide

	Sensor Type	These models are NOT polarity protected. Be sure to follow hook up instructions	Wire Leads	Prewired 9 ft. Part No.	Quick Disconnect Part No.*
Electrical Characteristics					
3/8" Dovetail	Reed (No LED)	0-120 VDC/VAC, 0.5 Amp Max current, 5 Watt Max, 0 Voltage Drop	2	949-200-001	949-200-301
	Reed (LED)	5-120 VDC/VAC, 0.03 Amp Max current, 4 Watt Max, 2.0 Voltage Drop	2	949-200-002	949-200-302
	Electronic (LED)	Sourcing PNP 6-24 VDC, 0.20 Amp Max current, 0.5 Voltage Drop	3	949-200-031	949-200-331
	Electronic (LED)	Sinking NPN 6-24 VDC, 0.20 Amp Max current, 0.5 Voltage Drop	3	949-200-032	949-200-332
1/4" Dovetail	Reed (No LED)	0-120 VDC/VAC, 0.5 Amp Max current, 5 Watt Max, 0 Voltage Drop	2	949-000-001	949-000-301
	Reed (LED)	5-120 VDC/VAC, 0.03 Amp Max current, 4 Watt Max, 2.0 Voltage Drop	2	949-000-002	949-000-302
	Electronic (LED)	Sourcing PNP 6-24 VDC, 0.20 Amp Max current, 0.5 Voltage Drop	3	949-000-031	949-000-331
	Electronic (LED)	Sinking NPN 6-24 VDC, 0.20 Amp Max current, 0.5 Voltage Drop	3	949-000-032	949-000-332

Round Profile Sensors

Round Profile Sensors feature surge suppression, polarity protection, LED indicator, and extremely fast switching speeds. These slide into mating 4mm keyhole slots adjacent to the cylinder port, and are easily positioned and locked in place with a set screw.

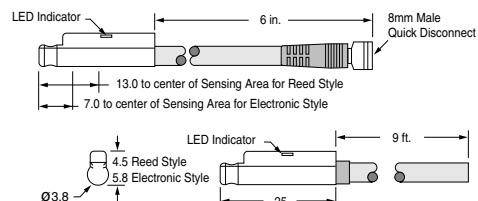

All round profile sensors feature surge suppression, polarity protection, LED indicator, and extremely fast switching speeds.

Ordering Guide

Round Profile Sensors – Electrical Characteristics							Part Numbers	
Sensor Type	Function	Switching Voltage	Switching Current	Switching Power	Switching Speed	Voltage Drop	Prewired 9 ft. Part No.	Quick Disconnect Part No.*
Reed Switch for PLC's w/LED (current limiting)	SPST Normally Open	5-120V AC/DC 50/60 Hz	0.04 Amp max 0.005 Amp min.	4 Watts max.	0.5 ms operate 0.1 ms release	2.5 Volts	9C49-000-002	9C49-000-302 Requires 3 pin cordset
Electronic LED and Sourcing	PNP Normally Open	6-30 VDC	0.2 Amp max.	6 Watts max.	1.5µs operate 0.5µs release	1.5 Volts	9C49-000-031	9C49-000-331 Requires 3 pin cordset
Electronic LED and Sinking	NPN Normally Open	6-30 VDC	0.2 Amp max.	6 Watts max.	1.5µs operate 0.5µs release	1.5 Volts	9C49-000-032	9C49-000-332 Requires 3 pin cordset

Note*: Quick Disconnect styles are supplied with 6 inch pigtail with male connector. Order female cordsets separately. See page 36.

Temperature Range for Sensors

-20° to +80° C (-4° to +176° F)

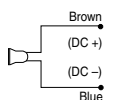

Reed Switch without LED

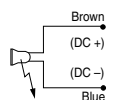

Reed Switch with LED

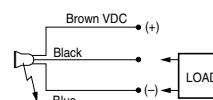

Electronic Sensor Sourcing

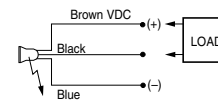

Electronic Sensor Sinking

Global Series™ Cylinders

Ø12 - Ø25 mm Bores – Standard Features

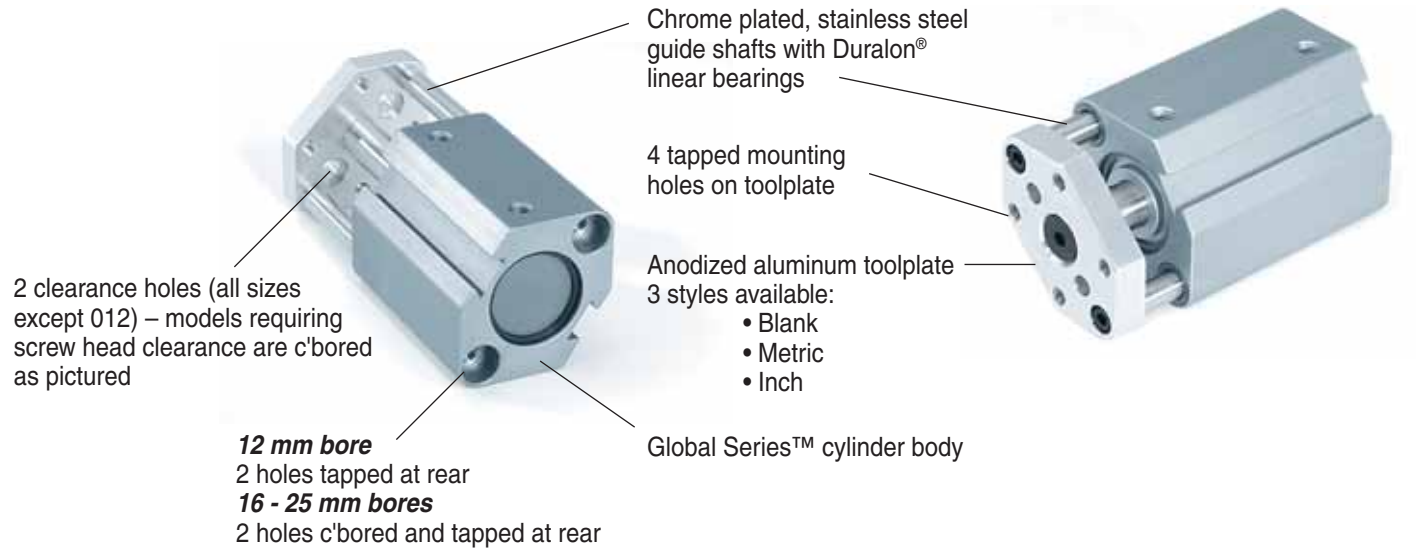

Ø32 - Ø100 mm Bores – Standard Features

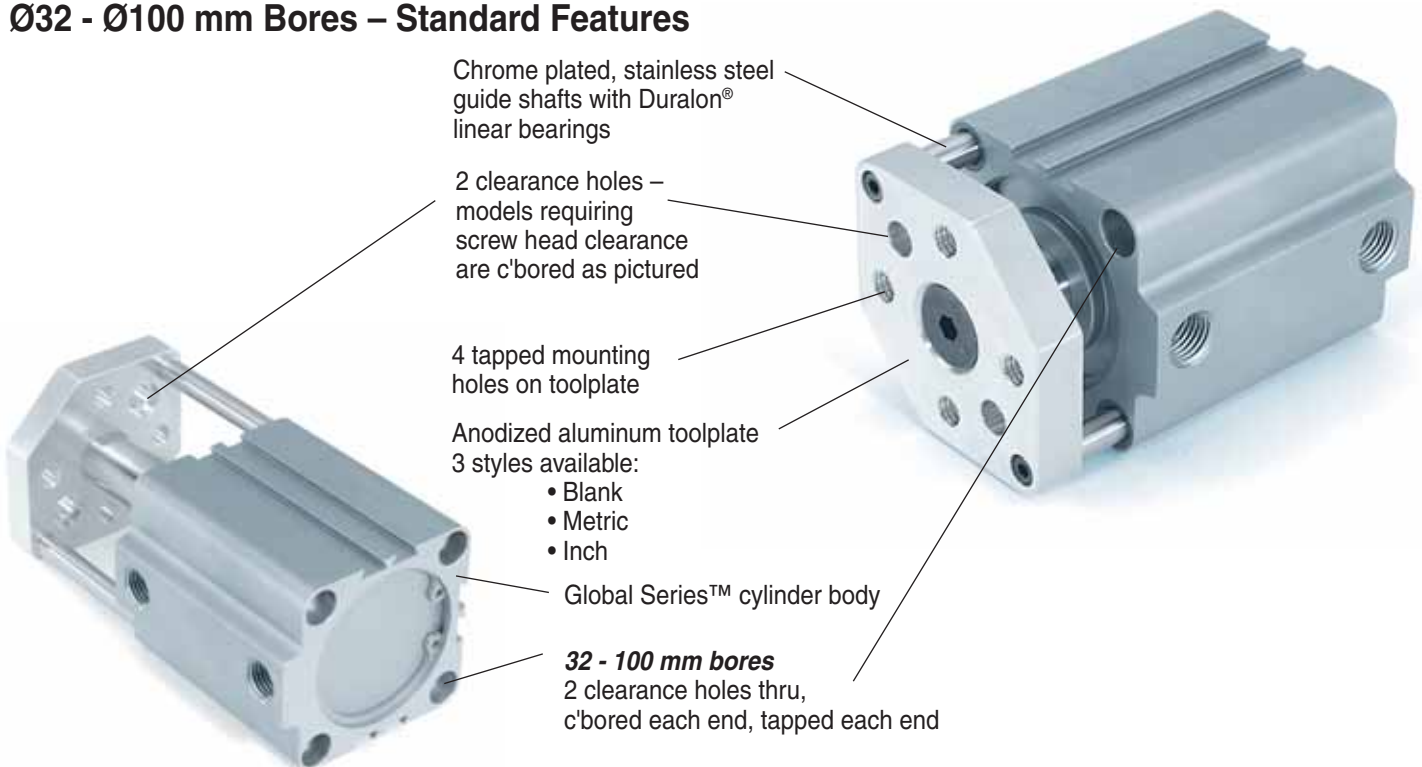

“GT” Series – Double Acting, Guided Toolplate Models

How to Order

GT – Global Series™
Guided Toolplate

N – without magnetic piston
D – with magnetic piston
Sensors & cables must be ordered separately. Please see page 37.

005 thru **150** – See data chart below for available standard strokes

“GT” Model Number

Series | **Port** | **Body** – | **Bore** – | **Stroke** – | **Options**

N – NPT ports and inch mounting holes in toolplate & cylinder
G – BSP Parallel ports and metric mounting holes in toolplate & cylinder
P – BSPT taper ports and metric mounting holes in toolplate & cylinder

10 bore sizes: 012 thru 100

B – Bumpers
V – Viton Seals
T1 – Blank toolplate

ORDERING EXAMPLES



GTND – 050 – 025 – V

Guided toolplate, NPT ports, inch mounting holes in toolplate and cylinder, magnetic piston, 50 mm bore, 25 mm stroke, Viton seals. (Sensors must be ordered separately. See page 37.)



GTGN – 025 – 020

Guided toolplate, BSP Parallel ports, metric mounting holes in toolplate and cylinder, 25 mm bore, 20 mm stroke, no options.

Engineering Data – See page 8 for additional specifications

Maximum Allowable Load at Toolplate – Kg. (Lbs)							
Bore mm (Nom. Inch)	Standard Available Cylinder Strokes mm (inch)						
	5 (.20)	10 (.39)	15 (.59)	20 (.79)	25 (.98)	30 (1.18)	35 (1.38)
12 (1/2)	3.54 (7.8)	2.72 (6)	1.36 (3)	1.14 (2.5)	0.95 (2.1)	0.86 (1.9)	–
16 (5/8)	4.99 (11)	4.09 (9)	2.13 (4.7)	1.86 (4.1)	1.54 (3.4)	1.32 (2.9)	–
20 (3/4)	7.72 (17)	7.26 (16)	4.99 (11)	4.09 (9)	3.18 (7)	2.81 (6.2)	2.59 (5.7)
25 (1)	8.17 (18)	7.49 (16.5)	5.45 (12)	4.77 (10.5)	4.09 (9)	3.41 (7.5)	2.72 (6)
32 (1-1/4)	10.90 (24)	9.08 (20)	7.04 (15.5)	6.13 (13.5)	4.99 (11)	4.54 (10)	3.63 (8)
40 (1-1/2)	11.80 (26)	9.99 (22)	7.72 (17)	6.45 (14.2)	5.31 (11.7)	4.81 (10.6)	3.90 (8.6)
50 (2)	–	15.66 (34.5)	14.07 (31)	12.71 (28)	11.35 (25)	10.44 (23)	9.99 (22)
63 (2-1/2)	–	25.42 (56)	22.70 (50)	21.11 (46.5)	17.25 (38)	14.98 (33)	13.17 (29)
80 (3-1/4)	–	38.59 (85)	35.82 (78.9)	33.14 (73)	30.87 (68)	28.60 (63)	26.79 (59)
100 (4)	–	42.00 (92.5)	38.59 (85)	35.87 (79)	33.60 (74)	31.33 (69)	29.51 (65)

Maximum Allowable Load at Toolplate – Kg. (Lbs)							
Bore mm (Nom. Inch)	Standard Available Cylinder Strokes mm (inch)						
	40 (1.57)	45 (1.77)	50 (1.97)	75 (2.95)	100 (3.94)	125 (4.92)	150 (5.91)
12 (1/2)	–	–	0.50 (1.1)	0.41 (0.9)	0.32 (0.7)	–	–
16 (5/8)	–	–	0.77 (1.7)	0.64 (1.4)	0.41 (0.9)	–	–
20 (3/4)	2.36 (5.2)	2.27 (5)	2.09 (4.6)	1.23 (2.7)	0.77 (1.7)	–	–
25 (1)	2.50 (5.5)	2.36 (5.2)	2.18 (4.8)	1.32 (2.9)	0.86 (1.9)	–	–
32 (1-1/4)	3.41 (7.5)	3.27 (7.2)	3.04 (6.7)	2.45 (5.4)	1.91 (4.2)	0.73 (1.6)	0.41 (0.9)
40 (1-1/2)	3.68 (8.1)	3.54 (7.8)	3.22 (7.1)	2.63 (5.8)	2.09 (4.6)	0.86 (1.9)	0.54 (1.2)
50 (2)	8.63 (19)	7.26 (16)	5.90 (13)	4.81 (10.6)	4.13 (9.1)	1.36 (3)	1.04 (2.3)
63 (2-1/2)	10.44 (23)	8.85 (19.5)	8.40 (18.5)	6.63 (14.6)	5.49 (12.1)	2.04 (4.5)	1.41 (3.1)
80 (3-1/4)	20.43 (45)	16.80 (37)	14.98 (33)	12.08 (26.6)	10.26 (22.6)	3.81 (8.4)	2.63 (5.8)
100 (4)	22.25 (49)	17.71 (39)	15.89 (35)	13.17 (29)	11.17 (24.6)	4.13 (9.1)	2.86 (6.3)

Global Series™ Cylinders

Ø12 – Ø25 mm Bores



Sensors for magnetic piston position indication must be ordered separately. See page 37.

Standard Toolplate will be provided when 'N' port code is specified.

will be provided when 'G' or 'P' port code is specified.

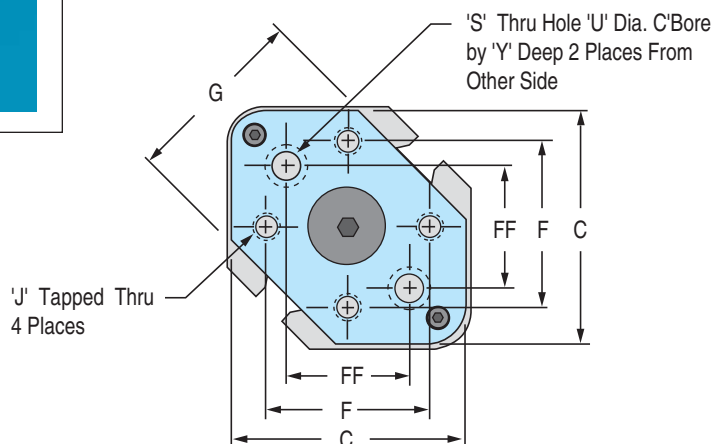

Dimensional Data

Toolplate & Mounting – Inch Dimensions Specified by Port Code 'N'

Bore mm	C	F	FF	G	J	OT	RT	S	U	Y
12	.94	.63	–	.82	6-32	8-32	.38	–	–	–
16	1.10	.81	.44	.98	6-32	8-32	.51	.14	–	–
20	1.38	1.06	.57	1.00	8-32	1/4-20	.53	.17	.28	.06
25	1.54	1.13	.66	1.18	8-32	1/4-20	.59	.17	–	–

Toolplate & Mounting – Metric Dimensions (mm) Specified by Port Code 'G' or 'P'

Bore mm	C	F	FF	G	J	OT	RT	S	U	Y
12	24	16.0	–	20.8	M3 x 0.5	M4 x 0.7	9.7	–	–	–
16	28	20.0	11.0	25.0	M4 x 0.7	M4 x 0.7	13.0	3.3	–	–
20	35	27.0	14.5	25.4	M4 x 0.7	M6 x 1.0	13.5	4.2	–	–
25	40	28.5	16.6	30.0	M4 x 0.7	M6 x 1.0	15.0	4.2	–	–

'B' Dimensions by Bore and Stroke for both Standard & Magnetic Piston shown as "mm (inches)"

Bore mm	Stroke mm									
	5	10	15	20	25	30	35	40	45	
12	33.0 (1.30)	38.0 (1.50)	43.0 (1.69)	48.0 (1.89)	53.0 (2.07)	58.0 (2.28)	–	–	–	–
16	35.5 (1.40)	40.5 (1.59)	45.5 (1.79)	50.5 (1.99)	55.5 (2.19)	60.5 (2.38)	–	–	–	–
20	36.5 (1.44)	41.5 (1.63)	46.5 (1.83)	51.5 (2.03)	56.5 (2.22)	61.5 (2.42)	66.5 (2.62)	71.5 (2.81)	76.5 (3.01)	–
25	37.5 (1.48)	42.5 (1.67)	47.5 (1.87)	52.5 (2.07)	57.5 (2.26)	62.5 (2.46)	67.5 (2.66)	72.5 (2.85)	77.5 (3.05)	–

"GT" Series – Guided Toolplate Models – Dimensions

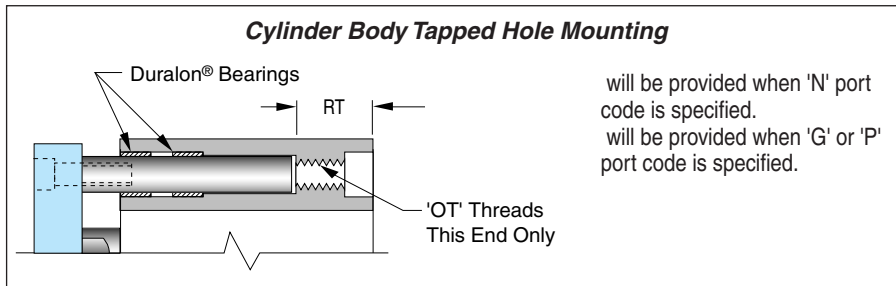

*** Port Size Offerings**

Note:
M5 x 0.8 port will accept
#10-32 male thread fittings

Blank Toolplate

Use Option Code T1 to specify a blank toolplate shown below.

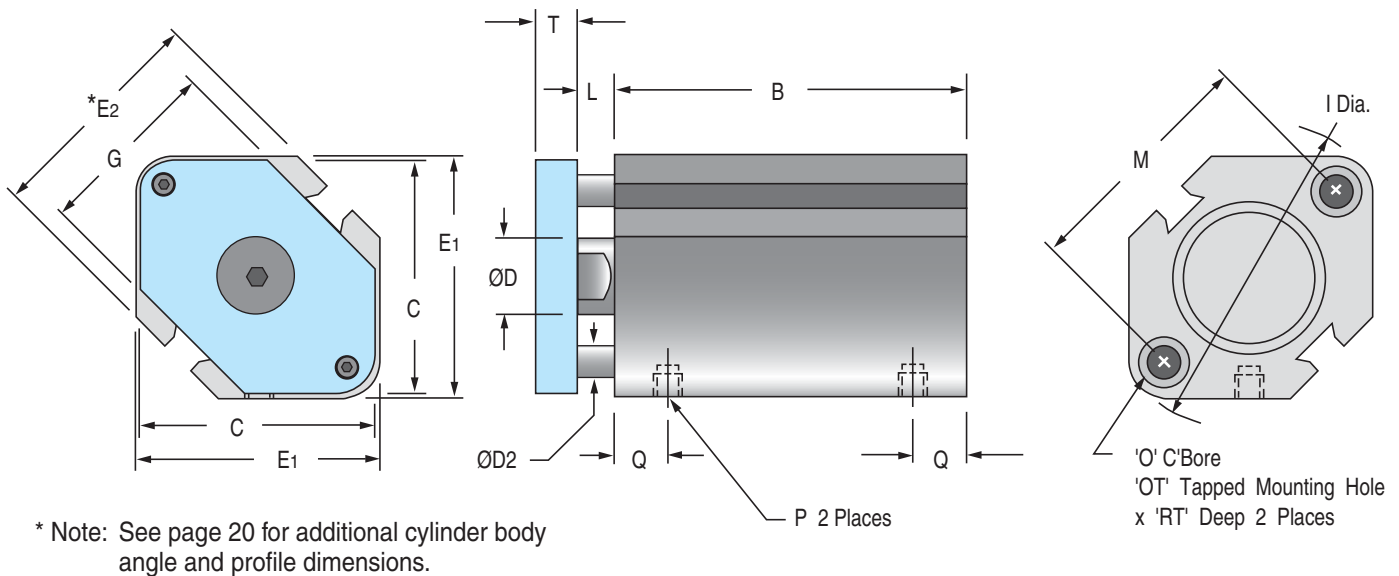

Chart Dimensions shown as "mm (inches)"

Bore mm	ØD	ØD2	E1	E2	I	L	M	O	*P	T
12	6 (0.236)	4.8 (0.188)	25 (0.98)	23 (0.90)	31.5 (1.24)	3.5 (0.14)	22 (0.87)	-	-	6.1 (.24)
16	8 (0.315)	5 (0.197)	29 (1.14)	27.2 (1.07)	37.1 (1.46)	3.5 (0.14)	28 (1.10)	6.5 x 3.5 dp (0.26 x 0.14 dp)	M5x0.8	6.1 (.24)
20	10 (0.394)	6 (0.236)	36 (1.42)	31.2 (1.23)	47 (1.85)	4.5 (0.18)	36 (1.42)	9.0 x 7.0 dp (0.35 x 0.28 dp)	M5x0.8	6.9 (.27)
25	12 (0.472)	6 (0.236)	40 (1.57)	36.9 (1.45)	51.3 (2.02)	5 (0.20)	40 (1.57)	9.0 x 7.0 dp (0.35 x 0.28 dp)	M5x0.8	8.3 (.33)

	50	75	100	Bore mm
	83.8 (3.30)	108.8 (4.28)	133.8 (5.27)	12
	86.2 (3.39)	111.2 (4.38)	136.2 (5.36)	16
	81.5 (3.21)	116.6 (4.59)	141.6 (5.57)	20
	82.5 (3.25)	122.5 (4.82)	147.5 (5.81)	25

"Q" Port Location by Bore & Stroke

Bore mm	Stroke mm			
	5 – 45	50	75	100
12	7.0 (0.28)	8.9 (0.35)	8.9 (0.35)	8.9 (0.35)
16	7.8 (0.31)	10.2 (0.40)	10.2 (0.40)	10.2 (0.40)
20	8.1 (0.32)	8.1 (0.32)	12.1 (0.48)	12.1 (0.48)
25	8.4 (0.33)	8.4 (0.33)	12.7 (0.50)	12.7 (0.50)

Global Series™ Cylinders

Ø32 – Ø100 mm Bores



Standard Toolplate

Inch threads will be provided when 'N' port code is specified.
Metric threads will be provided when 'G' or 'P' port code is specified.

Blank Toolplate

Use Option Code T1 to specify a blank toolplate shown below.

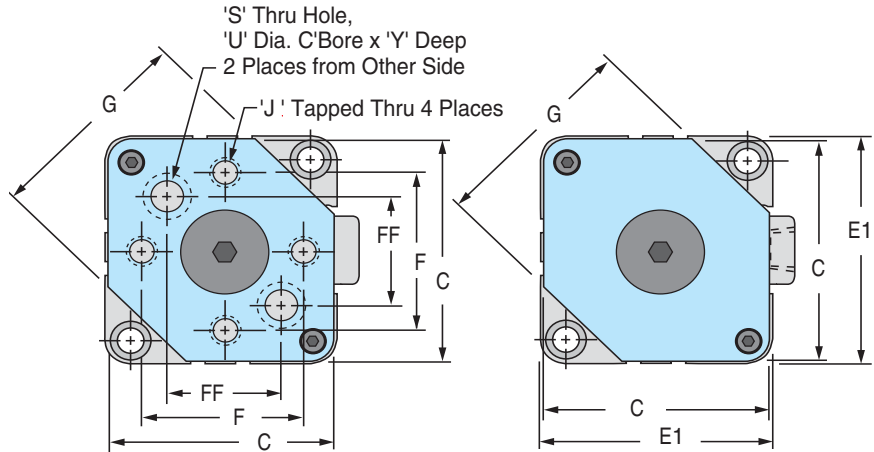

Dimensional Data

Toolplate & Mounting – Inch Dimensions Specified by Port Code 'N'

Bore mm	C	F	FF	G	J	OT	RT	S	U	Y
32	1.71	1.19	.84	1.44	10-24	1/4-20	.67	.20	–	–
40	2.00	1.38	.97	1.78	1/4-20	1/4-20	.75	.26	–	–
50	2.47	1.75	1.24	2.25	5/16-18	5/16-18	.75	.33	.49	.10
63	2.98	2.00	1.41	2.69	7/16-14	7/16-14	.87	.45	.68	.18
80	3.81	2.75	1.95	3.50	1/2-13	1/2-13	1.13	.52	.77	.18
100	4.50	3.25	2.30	4.45	1/2-13	1/2-13	1.13	.52	.77	.13

Toolplate & Mounting – Metric Dimensions (mm) Specified by Port Code 'G' or 'P'

Bore mm	C	F	FF	G	J	OT	RT	S	U	Y
32	43.4	30.0	21.2	36.7	M5x 0.8	M6x1.0	17.0	5.2	–	–
40	50.5	35.0	24.7	45.1	M6x1.0	M6x1.0	19.0	6.1	–	–
50	62.7	45.5	32.2	57.1	M8x1.25	M8x1.25	19.0	8.2	13.5	2.5
63	75.7	50.5	35.7	68.3	M10x1.5	M10x1.5	22.0	11.5	16.5	3.3
80	96.9	70.0	49.5	88.9	M12x1.75	M12x1.75	29.0	12.3	18.5	3.8
100	114.4	82.5	58.3	112.9	M12x1.75	M12x1.75	29.0	12.3	18.5	3.2

'B' Dimension by Bore & Stroke shown as "mm (inches)"

Bore mm	Stroke mm									
	5	10	15	20	25	30	35	40	45	
32 St'd Piston	28.0 (1.10)	33.0 (1.30)	38.0 (1.50)	43.0 (1.69)	48.0 (1.89)	53.0 (2.09)	58.0 (2.28)	63.0 (2.48)	68.0 (2.68)	73.0 (2.87)
32 Mag. Piston	38.0 (1.50)	43.0 (1.69)	48.0 (1.89)	53.0 (2.09)	58.0 (2.28)	63.0 (2.48)	68.0 (2.68)	73.0 (2.87)	78.0 (3.07)	83.0 (3.27)
40 St'd Piston	34.5 (1.36)	39.5 (1.56)	44.5 (1.75)	49.5 (1.95)	54.5 (2.15)	59.5 (2.34)	64.5 (2.54)	69.5 (2.74)	74.5 (2.93)	79.5 (3.13)
40 Mag. Piston	44.5 (1.75)	49.5 (1.95)	54.5 (2.15)	59.5 (2.34)	64.5 (2.54)	69.5 (2.74)	74.5 (2.93)	79.5 (3.13)	84.5 (3.33)	89.5 (3.53)
50 St'd Piston	–	40.5 (1.59)	45.5 (1.79)	50.5 (1.99)	55.5 (2.19)	60.5 (2.38)	65.5 (2.58)	70.5 (2.78)	75.5 (2.97)	80.5 (3.17)
50 Mag. Piston	–	50.5 (1.99)	55.5 (2.19)	60.5 (2.38)	65.5 (2.58)	70.5 (2.78)	75.5 (2.97)	80.5 (3.17)	85.5 (3.37)	90.5 (3.57)
63 St'd Piston	–	46.0 (1.81)	51.0 (2.01)	56.0 (2.20)	61.0 (2.40)	66.0 (2.60)	71.0 (2.80)	76.0 (2.99)	81.0 (3.19)	86.0 (3.39)
63 Mag. Piston	–	56.0 (2.20)	61.0 (2.40)	66.0 (2.60)	71.0 (2.80)	76.0 (2.99)	81.0 (3.19)	86.0 (3.39)	91.0 (3.58)	96.0 (3.78)
80 St'd Piston	–	53.5 (2.11)	58.5 (2.30)	63.5 (2.50)	68.5 (2.70)	73.5 (2.89)	78.5 (3.09)	83.5 (3.29)	88.5 (3.48)	93.5 (3.68)
80 Mag. Piston	–	63.5 (2.50)	68.5 (2.70)	73.5 (2.89)	78.5 (3.09)	83.5 (3.29)	88.5 (3.48)	93.5 (3.68)	98.5 (3.88)	103.5 (4.08)
100 St'd Piston	–	63.0 (2.48)	68.0 (2.68)	73.0 (2.87)	78.0 (3.07)	83.0 (3.27)	88.0 (3.46)	93.0 (3.66)	98.0 (3.86)	103.0 (4.06)
100 Mag. Piston	–	73.0 (2.87)	78.0 (3.07)	83.0 (3.27)	88.0 (3.46)	93.0 (3.66)	98.0 (3.86)	103.0 (4.06)	108.0 (4.25)	113.0 (4.45)

"GT" Series – Guided Toolplate Models – Dimensions

Cylinder Body Tapped Hole Mounting

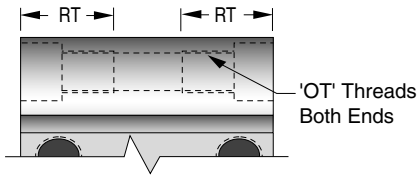

will be provided when 'N' port code is specified.
will be provided when 'G' or 'P' port code is specified.

* Port Size Offerings - See dimension column "P" below

- N**– NPT ports, inch toolplate & mounting threads
 - G**– BSP parallel ports, metric toolplate & mounting threads
 - P**– BSPT taper ports, metric toolplate & mounting threads
- ‡ Note: On 32 bore, 5mm stroke, non-magnetic model only, port thread is M5x0.8 which will accept #10-32 male thread fittings.

Ø32 – Ø100mm Bores

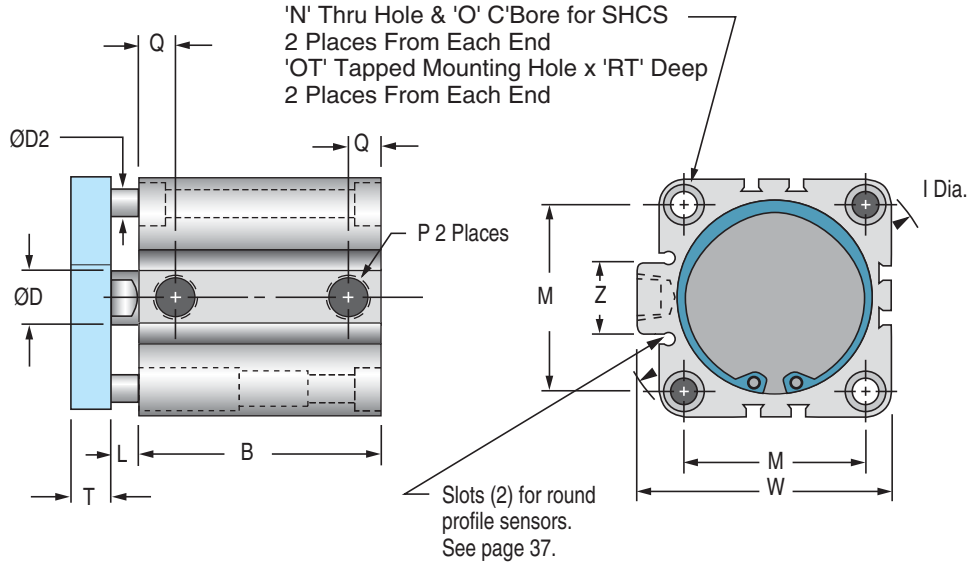

Chart Dimensions shown as "mm (inches)"

Bore mm	ØD	ØD2	E1	I	L	M	N	O	*P	T	W	Z
32	16 (0.630)	7 (0.276)	44.5 (1.75)	58.9 (2.32)	7 (0.28)	34 (1.34)	5.5 (0.22)	9.0 x 7.0 dp (0.35 x 0.28 dp)	1/8*‡	8.3 (0.33)	49.3 (1.94)	16.5 (0.65)
40	16 (0.630)	7 (0.276)	52 (2.05)	69 (2.72)	7 (0.28)	40 (1.57)	5.5 (0.22)	9.0 x 7.0 dp (0.35 x 0.28 dp)	1/8*	8.3 (0.33)	57.0 (2.24)	17.8 (0.70)
50	20 (0.787)	8 (0.315)	63.7 (2.51)	84.9 (3.34)	8 (0.31)	50 (1.97)	6.6 (0.26)	11.0 x 8.0 dp (0.43 x 0.31 dp)	1/4*	12.1 (0.48)	70.6 (2.78)	22.2 (0.88)
63	20 (0.787)	11.1 (0.438)	76.7 (3.02)	101.8 (4.01)	8 (0.31)	60 (2.36)	9 (0.35)	13.7 x 10.5 dp (0.54 x 0.41 dp)	1/4*	12.5 (0.49)	83.6 (3.29)	22.2 (0.88)
80	25 (0.984)	16 (0.630)	97.8 (3.85)	129.8 (5.11)	10 (0.39)	77 (3.03)	11 (0.43)	16.8 x 13.5 dp (0.66 x 0.53 dp)	3/8*	14.0 (0.55)	104 (4.09)	27.0 (1.06)
100	30 (1.181)	16 (0.630)	115.3 (4.54)	153.9 (6.06)	12 (0.47)	94 (3.70)	11 (0.43)	16.8 x 13.5 dp (0.66 x 0.53 dp)	3/8*	14.0 (0.55)	121.9 (4.80)	27.0 (1.06)

'B' Dimension by Bore & Stroke shown as "mm (inches)"

Bore mm	Stroke mm				
	50	75	100	125	150
32 St'd Piston	73.0 (2.87)	108.0 (4.25)	133.0 (5.24)	172.8 (6.80)	197.8 (7.79)
32 Mag. Piston	83.0 (3.27)	108.0 (4.25)	133.0 (5.24)	172.8 (6.80)	197.8 (7.79)
40 St'd Piston	79.5 (3.13)	114.5 (4.51)	139.5 (5.49)	180.5 (7.11)	205.5 (8.09)
40 Mag. Piston	89.5 (3.52)	114.5 (4.51)	139.5 (5.49)	180.5 (7.11)	205.5 (8.09)
50 St'd Piston	80.5 (3.17)	115.5 (4.55)	140.5 (5.53)	184.3 (7.26)	209.3 (8.24)
50 Mag. Piston	90.5 (3.56)	115.5 (4.55)	140.5 (5.53)	184.3 (7.26)	209.3 (8.24)
63 St'd Piston	86.0 (3.39)	121.0 (4.76)	146.0 (5.75)	189.6 (7.46)	214.6 (8.49)
63 Mag. Piston	96.0 (3.78)	121.0 (4.76)	146.0 (5.75)	189.6 (7.46)	214.6 (8.49)
80 St'd Piston	93.5 (3.68)	128.5 (5.06)	153.5 (6.04)	194.5 (7.66)	219.5 (8.64)
80 Mag. Piston	103.5 (4.07)	128.5 (5.06)	153.5 (6.04)	194.5 (7.66)	219.5 (8.64)
100 St'd Piston	103.0 (4.06)	138.0 (5.43)	163.0 (6.42)	201.7 (7.94)	226.7 (8.93)
100 Mag. Piston	113.0 (4.45)	138.0 (5.43)	163.0 (6.42)	201.7 (7.94)	226.7 (8.93)

"Q" Port Location by Bore & Stroke

Bore mm	Stroke mm	
	5 – 100	125, 150
32	8.7 (0.34)	12.7 (0.50)
40	9.2 (0.36)	12.7 (0.50)
50	10.5 (0.41)	13.2 (0.52)
63	11.5 (0.45)	18.5 (0.73)
80	14.0 (0.55)	14.0 (0.55)
100	18.0 (0.71)	18.0 (0.71)

Global Series™ List Prices
Effective September 1, 2011

N- NPT ports, inch rod thread
 G- BSP Parallel ports, metric rod thread
 P- BSPT taper ports, metric rod thread

G- Global Series™

N- without magnetic piston (std)
 D- with magnetic piston (adder)
 See sensors, cables and accessory prices on page 47

How to Order

D- double acting
 S- single acting, spring retract - 012 thru 050 bore only
 T- single acting, spring extend - 012 thru 050 bore only

Series	Port	Body	Model	Mounting	Bore	Stroke	Action	Options
--------	------	------	-------	----------	------	--------	--------	---------

S- single rod (standard)
 W- double rod
 T- double rod hole thru
 K- non-rotating single rod
 L- non-rotating double rod
 M- non-rotating double rod hole thru
 A- adjustable stroke extend (includes Mounting Code A - tapped holes)

B- thru hole (standard)
 L- foot mount
 E- flange rod end
 F- flange cap end
 G- ISO flange rod end
 H- ISO flange cap end
 C- rear clevis
 A- tapped both ends
 See prices on page 47

012
 •
 •
 •
 •
 •
 •
 •
 •
 100

005
 •
 •
 •
 •
 •
 •
 •
 •
 150

B- bumpers, both ends
 M- male rod, rod end
 N- male rod, cap end
 P- male rod, both ends
 E- boss, rod end
 F- boss, cap end
 RS- adjustable stroke, retract
 V- high temperature seals

Bore mm	Stroke mm	Action Code (Base Price)			Add on Prices							Option Code														
		D	S	T	Model Code					Magnet Piston Code D	Option Code															
					W	T	K	L	M		A	B	M or N	P	E or F	RS	V	XC10	XC11 XC12							
12	5	28.15	23.40	26.40																						
	10	29.30	23.75	26.85																						
	15	30.40	-	-																						
	20	31.45	-	-	9.40	N/A	41.25	51.40	N/A	N/A	5.05															
	25	32.55	-	-																						
	30	34.80	-	-																						
	50	41.00	-	-																						
	75	44.15	-	-																						
	100	47.85	-	-																						
	16	5	32.05	28.60	30.20																					
10		33.15	29.50	32.20																						
15		34.25	-	-																						
20		35.35	-	-																						
25		36.40	-	-	12.20	21.90	48.00	61.00	71.30	N/A	6.30															
30		38.65	-	-																						
50		42.25	-	-																						
75		45.35	-	-																						
100		49.10	-	-																						
20		5	38.50	34.40	36.35																					
	10	39.60	35.40	37.35																						
	15	40.65	-	-																						
	20	41.80	-	-																						
	25	42.90	-	-	15.00	24.60	48.00	64.00	74.35	N/A	8.20															
	30	43.90	-	-																						
	35	45.00	-	-																						
	40	45.05	-	-																						
	45	46.10	-	-																						
	50	48.00	-	-																						
25	5	43.75	34.80	29.35																						
	10	44.95	36.15	37.15																						
	15	46.20	-	-																						
	20	47.35	-	-																						
	25	48.60	-	-																						
	30	49.80	-	-	19.60	29.30	48.00	68.90	79.30	N/A	8.20															
	35	51.10	-	-																						
	40	52.25	-	-																						
	45	53.50	-	-																						
	32	5	48.85	37.70	39.05	21.35	31.10		70.95	81.20	-															
10		50.05	41.85	43.20	21.35	31.10		70.95	81.20	-																
15		51.35	-	-	21.35	31.10		70.95	81.20	60.80																
20		52.55	-	-	21.35	31.10		70.95	81.20	-																
25		53.75	-	-	21.35	31.10		70.95	81.20	60.80																
30		54.95	-	-	21.35	31.10		70.95	81.20	-																
35		56.25	-	-	23.55	33.25		73.15	83.55	-																
40		57.45	-	-	23.55	33.25	48.00	73.15	83.55	-	15.25															
45		58.65	-	-	23.55	33.25		73.15	83.55	-																
50		59.85	-	-	23.55	33.25		73.15	83.55	73.00																
75	66.00	-	-	23.55	33.25		73.15	83.55	87.45																	
100	72.15	-	-	23.55	33.25		73.15	83.55	99.70																	
125	85.65	-	-	23.55	33.25		73.15	83.55	112.40																	
150	98.40	-	-	23.55	33.25		73.15	83.55	124.10																	

N-NPT ports, inch rod thread
 G-BSP Parallel ports, metric rod thread
 P-BSPT taper ports, metric rod thread

N- without magnetic piston (std)
 D- with magnetic piston (adder)
See sensors, cables and accessory prices on page 47

How to Order

D- double acting
 S- single acting, spring retract - 012 thru 050 bore only
 T- single acting, spring extend - 012 thru 050 bore only

Series **Port** **Body** - **Model** **Mounting** **Bore** - **Stroke** **Action** - **Options**

G-Global Series™
 S- single rod (standard)
 W- double rod
 T- double rod hole thru
 K- non-rotating single rod
 L- non-rotating double rod
 M- non-rotating double rod hole thru
 A- adjustable stroke extend (includes Mounting Code A - tapped holes)

B- thru hole (standard)
 L- foot mount
 E- flange rod end
 F- flange cap end
 G- ISO flange rod end
 H- ISO flange cap end
 C- rear clevis
 A- tapped both ends
See prices on page 47

012
 •
 •
 •
 •
 •
 •
 •
 100
 005
 •
 •
 •
 •
 •
 •
 •
 •
 150

B- bumpers, both ends
 M- male rod, rod end
 N- male rod, cap end
 P- male rod, both ends
 E- boss, rod end
 F- boss, cap end
 RS- adjustable stroke, retract
 V- high temperature seals
 XC10- back-to-back
 XC11, XC12- tandem

Bore mm	Stroke mm	Action Code (Base Price)			Model Code						Magnet Piston	Option Code											
		D	S	T	W	T	K	L	M	A		B	M or N	P	E or F	RS	V	XC10	XC11 XC12				
40	5	58.00	44.85	46.45	22.25	33.85		66.50	78.95	-	Code D												
	10	59.25	45.85	47.40	22.25	33.85		66.50	78.95	-													
	15	60.60	-	-	22.25	33.85		66.50	78.95	60.80													
	20	61.80	-	-	22.25	33.85		66.50	78.95	-													
	25	63.10	-	-	22.25	33.85		66.50	78.95	60.80													
	30	64.35	-	-	22.25	33.85		66.50	78.95	-		15.25											
	35	65.75	-	-	25.50	37.10	48.00	70.00	82.35	-			8.95	2.55	5.10	N/C	27.55	8.95	36.10	43.00			
	40	67.05	-	-	25.50	37.10		70.00	82.35	-													
	45	68.25	-	-	25.50	37.10		70.00	82.35	-													
	50	69.55	-	-	25.50	37.10		70.00	82.35	73.00													
	75	75.95	-	-	25.50	37.10		70.00	82.35	87.45													
	100	82.50	-	-	25.50	37.10		70.00	82.35	99.70													
125	94.15	-	-	25.50	37.10		70.00	82.35	112.40														
150	107.50	-	-	25.50	37.10		70.00	82.35	124.10														
50	10	71.60	63.05	66.40	40.60	52.15		86.05	98.45	-	20.20												
	15	73.35	-	-	40.60	52.15		86.05	98.45	91.20													
	20	75.00	66.40	69.15	40.60	52.15		86.05	98.45	-													
	25	76.70	-	-	40.60	52.15		86.05	98.45	91.20													
	30	78.35	-	-	40.60	52.15		86.05	98.45	-													
	35	80.05	-	-	49.60	61.20	48.00	95.70	108.20	-		8.95	6.40	12.85	N/C	27.55	11.05	49.95	54.35				
	40	81.70	-	-	49.60	61.20		95.70	108.20	-													
	45	83.35	-	-	49.60	61.20		95.70	108.20	-													
	50	85.05	-	-	49.60	61.20		95.70	108.20	109.65													
	75	93.40	-	-	49.60	61.20		95.70	108.20	128.05													
	100	101.75	-	-	49.60	61.20		95.70	108.20	146.30													
	125	111.45	-	-	49.60	61.20		95.70	108.20	164.80													
150	126.00	-	-	49.60	61.20		95.70	108.20	183.10														
63	10	84.80	-	-	47.05	58.60		93.65	105.35	-	20.20												
	15	86.65	-	-	47.05	58.60		93.65	105.35	91.20													
	20	88.35	-	-	47.05	58.60		93.65	105.35	-													
	25	90.20	-	-	47.05	58.60		93.65	105.35	91.20													
	30	91.95	-	-	47.05	58.60		93.65	105.35	-													
	35	93.75	-	-	54.40	65.95	48.00	100.90	113.25	-		10.75	6.40	12.85	N/C	27.55	12.65	53.15	77.05				
	40	95.55	-	-	54.40	65.95		100.90	113.25	-													
	45	97.40	-	-	54.40	65.95		100.90	113.25	-													
	50	99.25	-	-	54.40	65.95		100.90	113.25	109.65													
	75	108.15	-	-	54.40	65.95		100.90	113.25	128.05													
	100	117.25	-	-	54.40	65.95		100.90	113.25	146.30													
	125	154.00	-	-	54.40	65.95		100.90	113.25	164.80													
150	165.45	-	-	54.40	65.95		100.90	113.25	183.10														
80	10	105.95	-	-	47.05	58.60		104.55	119.60	-	24.70												
	15	107.95	-	-	47.05	58.60		104.55	119.60	91.20													
	20	110.05	-	-	47.05	58.60		104.55	119.60	-													
	25	112.15	-	-	47.05	58.60		104.55	119.60	91.20													
	30	114.15	-	-	47.05	58.60		104.55	119.60	-													
	35	116.20	-	-	54.40	65.95	59.25	118.80	134.00	-		16.50	8.50	16.90	N/C	28.75	14.95	64.45	79.00				
	40	118.20	-	-	54.40	65.95		118.80	134.00	-													
	45	120.35	-	-	54.40	65.95		118.80	134.00	-													
	50	122.40	-	-	54.40	65.95		118.80	134.00	109.65													
	75	132.60	-	-	54.40	65.95		118.80	134.00	128.05													
	100	143.00	-	-	54.40	65.95		118.80	134.00	146.30													
	125	157.05	-	-	54.40	65.95		118.80	134.00	164.80													
150	172.75	-	-	54.40	65.95		118.80	134.00	183.10														
100	10	158.45	-	-	49.95	64.05		147.15	159.60	-	36.70												
	15	161.00	-	-	49.95	64.05		147.15	159.60	91.20													
	20	163.60	-	-	49.95	64.05		147.15	159.60	-													
	25	166.15	-	-	49.95	64.05		147.15	159.60	91.20													
	30	168.75	-	-	49.95	64.05		147.15	159.60	-													
	35	171.25	-	-	55.60	69.70	71.70	164.15	171.05	-		18.95	9.85	19.90	N/C	36.85	31.80	72.10	88.45				
	40	173.90	-	-	55.60	69.70		164.15	171.05	-													
	45	176.55	-	-	55.60	69.70		164.15	171.05	-													
	50	179.10	-	-	55.60	69.70		164.15	171.05	109.65													
	75	191.95	-	-	55.60	69.70		164.15	171.05	128.05													
	100	204.80	-	-	55.60	69.70		164.15	171.05	146.30													
	125	219.05	-	-	55.60	69.70		164.15	171.05	164.80													
150	235.75	-	-	55.60	69.70		164.15	171.05	183.10														

**“GT”
 Model
 Number**

GT- Global Series™
 Guided Toolplate

N- without magnetic piston (std)
 D- with magnetic piston (adder)
 See sensors, cables and
 accessory prices on page 47



N- NPT ports, inch threads toolplate & mounting
 G- BSP Parallel ports, metric threads toolplate & mounting
 P- BSPT taper ports, metric threads toolplate & mounting

B- Bumpers
 V- Viton Seals
 T1- Blank toolplate

Bore mm	Stroke mm	Base Price	Add on Prices			
			Magnetic Piston D	Option Codes		
				Bumpers B	Viton Seals V	Blank Toolplate T
12	5	68.20				
	10	69.30				
	15	70.50				
	20	71.70				
	25	72.85				
	30	75.35	5.65	6.20	3.95	N/C
	50	82.00				
	75	89.00				
	100	92.85				
	16	5	72.30			
10		73.40				
15		74.60				
20		75.75				
25		76.95	7.10	7.10	4.85	N/C
30		79.40				
50		83.30				
75		90.15				
100		94.25				
20		5	82.35			
	10	83.55				
	15	84.75				
	20	85.90				
	25	87.15				
	30	88.25	9.20	7.10	5.25	N/C
	35	89.35				
	40	89.50				
	45	90.50				
	50	92.50				
25	5	90.15				
	10	91.55				
	15	92.85				
	20	94.15				
	25	95.45				
	30	96.75	9.20	7.10	6.15	N/C
	35	98.05				
	40	99.40				
	45	100.65				
	50	102.75				
32	5	99.85				
	10	101.15				
	15	102.50				
	20	103.75				
	25	105.10				
	30	106.40				
	35	107.70	17.10	8.50	7.40	N/C
	40	109.00				
	45	110.30				
	50	111.65				
40	5	109.65				
	10	110.95				
	15	112.35				
	20	113.70				
	25	115.20				
	30	116.50	17.10	10.10	10.10	N/C
	35	117.85				
	40	119.25				
	45	120.60				
	50	121.95				
50	10	124.20				
	15	126.00				
	20	127.75				
	25	129.55				
	30	131.35	22.70	10.10	12.40	N/C
	35	133.15				
	40	134.95				
	45	136.70				
	50	138.55				
	75	155.25				
63	10	153.50				
	15	155.45				
	20	157.40				
	25	159.35				
	30	161.35				
	35	163.15				
	40	165.15	22.70	12.10	14.25	N/C
	45	168.00				
	50	169.00				
	75	194.85				
80	10	188.95				
	15	191.10				
	20	193.30				
	25	195.55				
	30	197.70				
	35	199.95				
	40	202.15	27.75	18.55	16.80	N/C
	45	204.40				
	50	206.55				
	75	241.00				
100	10	255.45				
	15	258.25				
	20	260.95				
	25	263.80				
	30	266.55				
	35	269.25				
	40	272.05	41.20	21.30	35.75	N/C
	45	274.75				
	50	277.50				
	75	315.75				

Mounting Codes, Accessories, & Sensors

Mounting Code Adders and Accessory Prices

Mounting Code Price Adders				
Bore mm	B	L, E, F, G or H	C	A
12	Std.	\$8.00	\$10.25	\$1.85
16	Std.	9.55	10.25	1.85
20	Std.	9.80	11.40	1.85
25	Std.	10.40	11.40	1.85
32	Std.	11.60	12.95	3.70
40	Std.	14.65	15.50	3.70
50	Std.	17.55	18.65	3.70
63	Std.	21.00	24.50	3.70
80	Std.	24.75	33.00	3.70
100	Std.	27.90	45.55	3.70

Accessory Prices				
Bore mm	Part No. [Use "RE" or "RC in box ()]	Rod Eye	Rod Clevis	
12	<input type="checkbox"/> -8-32-12 or <input type="checkbox"/> -M5 x 0.8	\$5.85	\$7.75	
16	<input type="checkbox"/> -8-32-16 or <input type="checkbox"/> -M6 x 1	6.60	8.30	
20	<input type="checkbox"/> -10-32 or <input type="checkbox"/> -M8 x 1.25	7.10	8.70	
25	<input type="checkbox"/> -1/4-28 or <input type="checkbox"/> -M10 x 1.25	9.05	11.70	
32	<input type="checkbox"/> -5/16-24 or <input type="checkbox"/> -M14 x 1.5	14.25	14.25	
40	<input type="checkbox"/> -3/8-24 or <input type="checkbox"/> -M14 x 1.5	14.80	16.60	
50	<input type="checkbox"/> -1/2-20 or <input type="checkbox"/> -M18 x 1.5	16.60	17.90	
63	<input type="checkbox"/> -1/2-20 or <input type="checkbox"/> -M18 x 1.5	16.60	17.90	
80	<input type="checkbox"/> -5/8-18 or <input type="checkbox"/> -M22 x 1.5	21.35	23.85	
100	<input type="checkbox"/> -3/4-16 or <input type="checkbox"/> -M26 x 1.5	25.20	29.35	

Dovetail Magnetic Sensors

Sensor Type	Electrical Characteristics	Wire Leads	Prewired 9 ft.		Quick Disconnect		
			Part No.	Price	Part No.	Price	
1/4" Dovetail	Reed (No LED)	0-120 VDC/VAC, 0.5 Amp Max, 5 Watt Max, 0 Voltage Drop	2	949-000-001	\$18.95	949-000-301	\$26.95
	Reed (LED)	5-120 VDC/VAC, 0.03 Amp Max, 4 Watt Max, 2.0 Voltage Drop	2	949-000-002	19.80	949-000-302	27.60
	Electronic (LED) Sourcing	PNP 6-24 VDC, 0.20 Amp Max, 0.5 Voltage Drop	3	949-000-031	25.00	949-000-331	32.85
	Electronic (LED) Sinking	NPN 6-24 VDC, 0.20 Amp Max, 0.5 Voltage Drop	3	949-000-032	25.00	949-000-332	32.85
3/8" Dovetail	Reed (No LED)	0-120 VDC/VAC, 0.5 Amp Max, 5 Watt Max, 0 Voltage Drop	2	949-200-001	\$21.15	949-200-301	\$29.10
	Reed (LED)	5-120 VDC/VAC, 0.03 Amp Max, 4 Watt Max, 2.0 Voltage Drop	2	949-200-002	21.95	949-200-302	30.40
	Electronic (LED) Sourcing	PNP 6-24 VDC, 0.20 Amp Max, 0.5 Voltage Drop	3	949-200-031	27.25	949-200-331	35.10
	Electronic (LED) Sinking	NPN 6-24 VDC, 0.20 Amp Max, 0.5 Voltage Drop	3	949-200-032	27.25	949-200-332	35.10

Round Profile Magnetic Sensors

These fit into the 4mm keyhole slots adjacent to the cylinder ports of the new extrusion shown on pages 21, 23, 25, 27, 29, 42 & 43.

The sensors feature surge suppression, polarity protection, LED indicator and extremely fast switching speeds.

Magnetic Sensors – Electrical Characteristics							Part Numbers and Prices			
Sensor Type	Function	Switching Voltage	Switching Current	Switching Power	Switching Speed	Voltage Drop	Prewired 9 ft. Part No.	Price	Quick Disconnect	Price
Reed Switch for PLC's w/LED (current limiting)	SPST Normally Open	5-120V AC/DC 50/60 Hz	0.04 Amp max 0.005 Amp min.	4 Watts max.	0.5 ms operate 0.1 ms release	2.5 Volts	9C49-000-002	\$20.25	9C49-000-302 Requires 3 pin cordset	\$27.00
Electronic LED and Sourcing	PNP Normally Open	6-30 VDC	0.2 Amp max.	6 Watts max.	1.5µs operate 0.5µs release	1.5 Volts	9C49-000-031	28.65	9C49-000-331 Requires 3 pin cordset	33.25
Electronic LED and Sinking	NPN Normally Open Normally Open	6-30 VDC	0.2 Amp max.	6 Watts max.	1.5µs operate 0.5µs release	1.5 Volts	9C49-000-032	28.65	9C49-000-332 Requires 3 pin cordset	33.25

8mm Female Cordsets

Cordset Description	Part No.	List Prices
1 meter length, 3 Pin	CFC-1M	\$15.60
2 meters length, 3 Pin	CFC-2M	16.85
5 meters length, 3 Pin	CFC-5M	21.30

Seal Kits

Bore	Seal Kit	Price	Non-rotating Seal Price
12	G12-SK	\$4.25	G12-DDS6V \$10.30
	G12-SKV	3.80	
16	G16-SK	4.35	G16-DDS8V 10.90
	G16-SKV	4.65	
20	G20-SK	4.45	G20-DDS10V 11.25
	G20-SKV	4.80	
25	G25-SK	4.60	G25-DDS12V 11.60
	G25-SKV	5.05	
32	G32-SK	5.10	G32-DDS16V 14.60
	G32-SKV	6.00	

Bore	Seal Kit	Price	Non-rotating Seal Price
40	G40-SK	\$6.00	G32-DDS16V \$14.60
	G40-SKV	9.65	
50	G50-SK	7.45	G50-DDS20V 15.10
	G50-SKV	13.35	
63	G63-SK	8.00	G50-DDS20V 15.10
	G63-SKV	14.20	
80	G80-SK	10.65	G80-DDS25V 16.40
	G80-SKV	21.40	
100	G100-SK	13.60	G100-DDS30 16.75
	G100-SKV	31.20	



FABCO-AIR, Inc. ■ 3716 N.E. 49th Avenue ■ Gainesville, FL 32609-1699
 ■ Telephone (352) 373-3578 ■ Fax (352) 375-8024 ■ E-Mail service@fabco-air.com
 ■ Web Site <http://www.fabco-air.com>

Fabco-Air Product Catalog Library

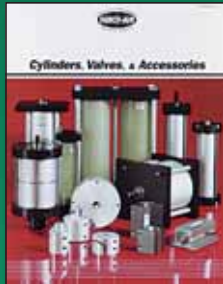

Cylinders, Valves and Accessories
Catalog # CV9

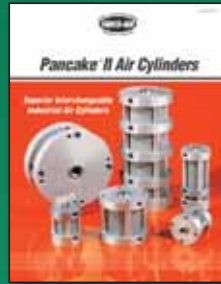

Pancake® II Air Cylinders
Catalog Pan2-2



Square Pancake® II Air Cylinders
Catalog # SqPan2



ISO 6431 Cylinders
Catalog # FAQR-09



Twin Rod, Non-Rotating Air Cylinders - Catalog # FDF-09 and Catalog # FDXS-09



Multi-Power® Air Presses
Catalog # FP16



Linear Slides - 6 Families
Catalog # LS-03

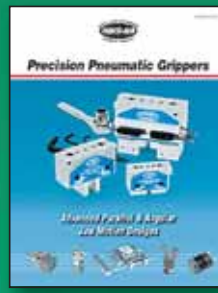

Pneumatic Grippers, Parallel Jaw and Angular Motion - Catalog # GR-8



Pneumatic Angular Grippers
Catalog # FKA-09



ISO 6432 Cylinders
Catalog # FAE-09



NFPA Interchangeable Air Cylinders - Catalog # NF-6

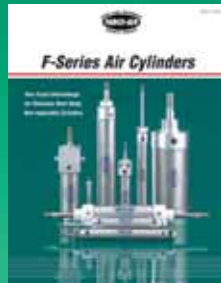

Stainless Steel Body Air Cylinders
Catalog # SSB-03



Swing Clamps
Bulletin # SC-DB04



Manifold Solenoid Valves
Catalog # FVS-Y-09

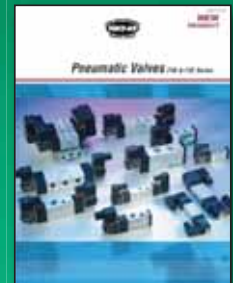

Air Pilot & Solenoid Valves
Catalog # FVA-E-09



Modular Air Preparation System - FRLs
Catalog # FRL-06



Stopper Cylinders
Catalog # ST-SC

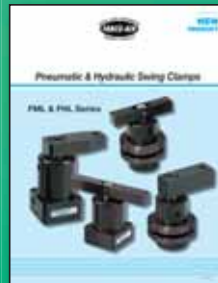

Swing Clamps, Pneumatic & Hydraulic
Catalog # FML-H

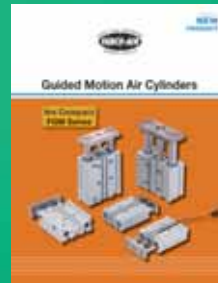

Guided Motion Air Cylinders
Catalog # FGM-10



Air Slide Tables
Catalog # FGXS-10